

Operating manual TR800Web

updated: 2017-11-23 Fu
from Firmware: 2.0.9 ...
Hardware Version -HW1

Universal-Relay TR800Web



Table of contents

1.	Application and short description	3
2.	Overview of functions	3
3.	Connection Plan	3
4.	Display and controls	4
5.	Important Information's	5
6.	Installation	6
7.	Detailed description	6
8.	Start-up operation (commissioning).....	7
8.1	General instructions on operating	7
8.2	Display mode	7
8.3	Menu mode	7
8.4	Info mode	7
8.5	Short operating diagram.....	8
8.6	Overview of commissioning.....	9
8.7	Switching on the unit	9
8.8	Connection to network and controls	9
8.9	Find the unit in the network	10
8.9.1	DHCP server	10
8.9.2	Default IP- Address 10.10.10.10	10
8.9.4	UPnP.....	11
8.9.5	Information about the login window.....	11
8.10	Make the basic network settings	12
8.11	Sensor settings	13
8.13	Alarm email	15
8.14	System	16
8.15	User management/access control.....	17
8.16	Logging and FTP Upload	18
8.17	View measurements and alarms, sensor simulation	20
8.18	Time-dependent control / Scheduler	22
9.	Ethernet protocols.....	23
9.1	UDP	23
9.2	Modbus TCP	23
9.3	SNMP.....	23
9.4	FTP Upload (Option)	23
9.5	AJAX data interface	23
10.	RS485 interface	23
10.1	Ziehl Standard Protocol.....	23
10.2	Modbus RTU.....	23
11.	Maintenance and Repair	23
12.	Troubleshooting	24
13.	Technical Data	25
14.	Housing design V8	28

1. Application and short description

Web-IO Universal Relay with Ethernet-interface and 8 inputs for temperature-sensors and other analogue signals.

The TR800Web can be connected to the internet or an intranet and operated via TCP/IP from a normal PC with a suitable browser (tested with IE 7, IE 8 and Firefox 3). No special software and no special instruction is required.

The Universal Relays TR 800 monitors and logs signals from up to 8 inputs.

Up to 8 limits (one per input) can be programmed for each of the 4 output-relays.

2. Overview of functions

- 8 measuring inputs:
 - Pt 100, Pt 1000 in 2- or 3-wire connection
 - KTY 83 or KTY 84
 - Thermocouples type B, E, J, K, L, N, R, S, T
 - DC 0-10 V, DC 0/4-20 mA
 - Resistance 500 Ohm, resistance 30 kOhm
- 4 relay-outputs (each potential-free change-over contact)
- Ethernet interface (http, https, UDP, Modbus, Bonjour, UpNP, SNMP, AJAX)
- RS485 interface (Standard Ziehl- and Modbus RTU- protocol)
- Universal power-supply AC/DC 24-240 V
- Integrated webserver for configuration, readout of measured data, user-management email-alarms, data- and alarm-logging and ftp-upload
- Time-dependent control (day/night)
- Real-time clock with synchronisation with timeserver
- Inputs S1 and S2 for switch or S0-interface

3. Connection Plan

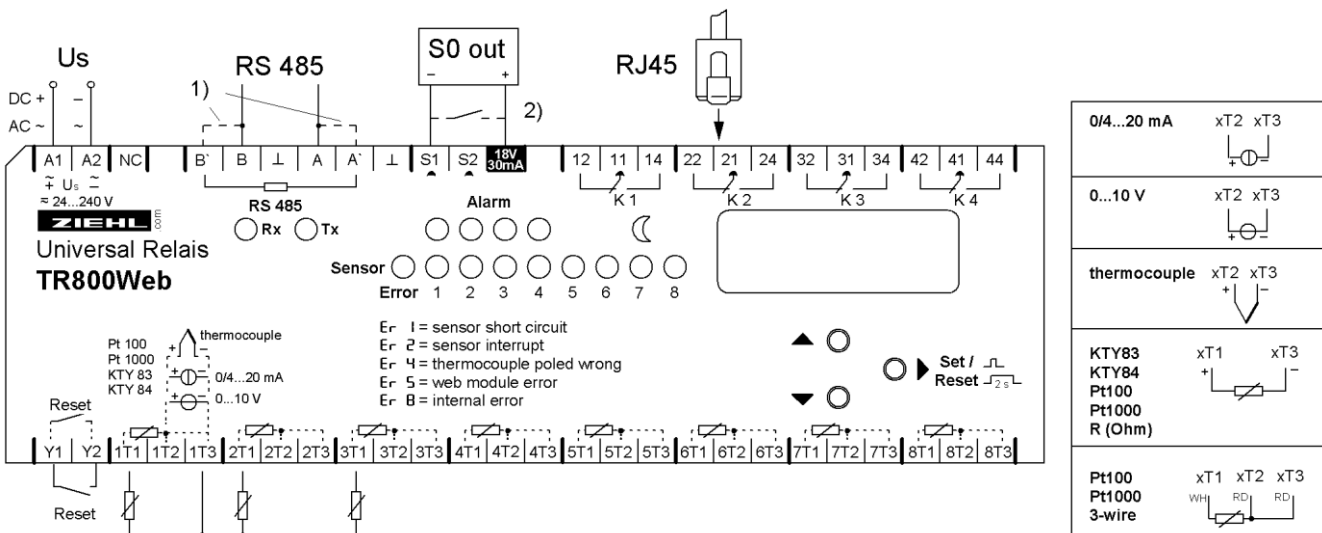

1) Terminating resistor active: Bridge A to A' and B to B'

The Terminals 1T3, 2T3, 3T3, 4T3, 5T3, 6T3, 7T3 and 8T3 are internally connected.

4. Display and controls

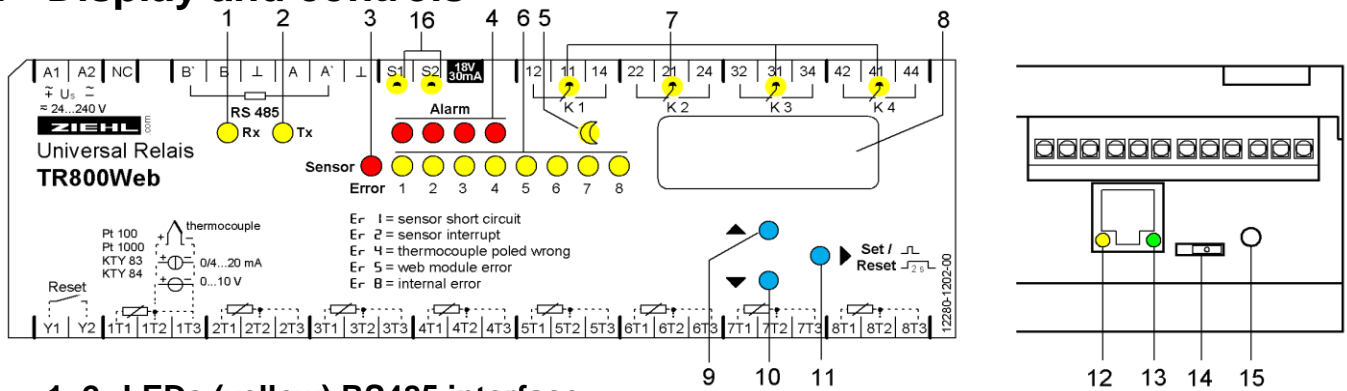

1, 2 LEDs (yellow) RS485 interface

- Rx flashes briefly: Unit is receiving data via the RS485 interface
- Tx flashes briefly: Unit is transmitting data via the RS485 interface
- Rx and Tx flash/illuminate during firmware update

3 LED (red) Sensor error

- Illuminated: Fault in a sensor circuit

4 LEDs (red) alarm

- Illuminated: Alarm (1-4) has occurred
- Flashes briefly (1:4): Response delay is running
- Flashes long (4:1): Backshift delay is running
- Flashes uniformly (1:1): Ready for reset, reset with key
Press "SET/RESET" ≥ 2s or ext. Reset Y1/Y2

5 LED (yellow) Night

- Illuminated: Limits for "Night" (can be set via browser) are active

6 LEDs (yellow) sensors

- Illuminated: Displays the sensor value belonging to the LED in the digital display
- Flashes: Sensor error in the corresponding sensor circuit

7 LEDs (yellow) relay state

- Illuminated: The relay belonging to the LED is picked up
- Off: The relay belonging to the LED is released

8 Digital display (4 digits)

- Display of sensor value, error codes
- Display of menu and configuration mode

9, 10 Up button / Down button

- Change into the menu mode (see Operating instructions Point 8.3)

11 Set/Reset button

- Press briefly: Displays the next sensor (sensor LED illuminates)
- Press for 10 s: Displays the software version (e.g. 0-00)

12 LED (yellow) Displays Ethernet transmission speed

- Off: 10 Mbps On: 100 Mbps

13 LED (green) Displays Ethernet data traffic

- Flashes during active data transmission

14 IP address slide switch

- Towards Ethernet jack: IP address 10.10.10.10
- Towards reset button: IP address User (set via web browser)

15 Webserver reset button

- Internal webserver restarts when pressed (duration ca. 1 minute)

16 LED (yellow) input state S1 and S2

- On: input Sx aktive

5. Important Information's

To use the equipment flawless and safe, transport and store properly, install and start professionally and operate as directed.

Only let persons work with the equipment who are familiar with installation, start and use and who have appropriate qualification corresponding to their function. They must observe the contents of the instructions manual, the information which are written on the equipment and the relevant security instructions for the setting up and the use of electrical units.

The equipments are built according to DIN / EN and checked and leave the plant according to security in perfect condition. To keep this condition, observe the security instructions with the headline „Attention“ written in the instructions manual. Ignoring of the security instructions may lead to death, physical injury or damage of the equipment itself and of other apparatus and equipment.

If, in any case the information in the instructions manual is not sufficient, please contact our company or the responsible representative.

Instead of the industrial norms and regulations written in this instructions manual valid for Europe, you must observe out of their geographical scope the valid and relevant regulations of the corresponding country.



DANGER!

Hazardous voltage!

Will cause death or serious injury. Turn off and lock out all power supplying this device before working on this device.

Observe the maximum temperature permissible when installing in switching cabinet. Make sure sufficient space to other equipment or heat sources. If the cooling becomes more difficult e.g. through close proximity of apparatus with elevated surface temperature or hindrance of the cooling air, the tolerable environmental temperature is diminishing.



ATTENTION! Connection of sensors

The inputs 1T1, 1T2, 1T3 to 8T3 and RESET Y1, Y2 and S1, S2 are not potentially separated from output RS485. Temperature-sensors must have sa sufficient insulation.

Only signals according to SELV (Safety Extra Low Voltage) may be connected.

The pluggable terminals of the measuring inputs have a special contact-material and may only be used for the connection of the sensors.

Attention! Universal power supply

The unit is equipped with a universal power supply, which is suitable for DC- and AC-voltages. Before connecting the unit to the current, make sure that the allowed scope of voltage of the control voltage U_s , written on the lateral type plate, corresponds to the supply voltage of the unit.



ATTENTION! When all relays are programmed in operation current mode (= pick up at alarm), a loss of the supply voltage or an instrument failure can remain unidentified.

When the relay is applied as control instrument, the operator must ensure, that this error is recognized by regular examinations.

We recommend to program and accordingly evaluate at least one relay in the closed-circuit current mode.

6. Installation

The unit can be installed as follows:

- Installation in switchgear cabinet on 35 mm mounting rail according to EN 60715
- With screws M4 for installation on walls or panel. (additional latch not included in delivery)
Connection according to connection plan or type plate.



A circuit-breaker or switch must be situated within easy reach of the unit and fused. Installation excess current protection should be ≤ 10 A.

7. Detailed description

- The TR800Web measures up to 8 connected sensors, displays the measured values and evaluates them.
- Configuration and operation are performed with a computer through a web browser
- A setting can be made for each sensor
 - Assignment limit \leftrightarrow Alarm (as desired)
 - Alarm active / inactive
 - Limit for alarm on
 - Limit for alarm off
- For Relays K1 .. K4 (Alarm 1 .. Alarm 4) can be set individually
 - Response delay and switch-back delay
 - Relay on/off during alarm (operating or closed-circuit current)
 - Alarm during error (message about sensor errors and device errors)
 - Alarm locked, (To reset, press "SET" ≥ 2 s or ext. reset Y1/Y2)
- Ethernet interface for
 - http and https (under http, port can be set and switched off)
 - UDP protocol to read out data (port adjustable)
 - Modbus protocol to read data
- RS485 interface for
 - standard Ziehl protocol to read data
 - Modbus RTU protocol to read data
- Via the web browser, the following functions are available
 - Display measurement, min and max values with date/timestamp
 - Sensor simulation for simulating individual sensors
 - Alarm status display
 - Sensor configuration (name, type, compensation, scale and unit)
 - Alarm configuration (limits, operating/no-load current, alarm during error, alarm locked, response /switch-back delay and email)
 - Time-controlled day/night limits switchover
 - Data logging, alarm logging and parameter logging with date/timestamp
 - Network configuration
 - System settings
 - User management

8. Start-up operation (commissioning)

8.1 General instructions on operating

One can identify the device operating mode with the decimal point behind the last 7-segment display.

8.2 Display mode

Decimal point off (normal state for measurement display)

	Displays the current sensor value (related yellow sensor LED illuminated, change to next sensor by pressing Set -> button)
LED yellow RS485 Rx / Tx	Flashes during data communication via RS485 interface
LED yellow Day / Night	ON = Limits for "Night" are active OFF = Limits for "Day" are active
LED yellow Relay K1 .. K4	ON = Relay operating OFF = Relay is released
LED red Alarm 1 .. 4	Flashes 1:4 = Response delay is active Flashes 4:1 = switch-back delay is active Flashes 1:1 = Ready for switch back, reset with press "SET/RESET" button $\geq 2s$ or close ext. Reset Y1/Y2 On = Alarm on OFF = Alarm off
LED yellow Sensor 1 .. 8	ON = Measurement of selected sensors in the display. Flashes = Error in sensor circuit
LED red Sensor error	On = Fault in a sensor circuit (Defective, yellow sensor LED flashes)
Function key Set/Reset	Press briefly: Displays the next sensor (sensor LED illuminates) Press for 10 s: displays the software version
Function keys Up and Down	Press briefly: Change into the menus mode

8.3 Menu mode

Decimal point on

	Select the menu items to view the parameters
Function keys Up and Down	Press briefly: Select menu item; change into the display mode
Function keys Set/Reset	Press briefly: Change into the configuration mode

8.4 Info mode

Decimal point flashes

Function keys Up and Down	Not in use
Function keys Set/Reset	Select next parameter; after the last parameter change into menu mode

8.5 Short operating diagram

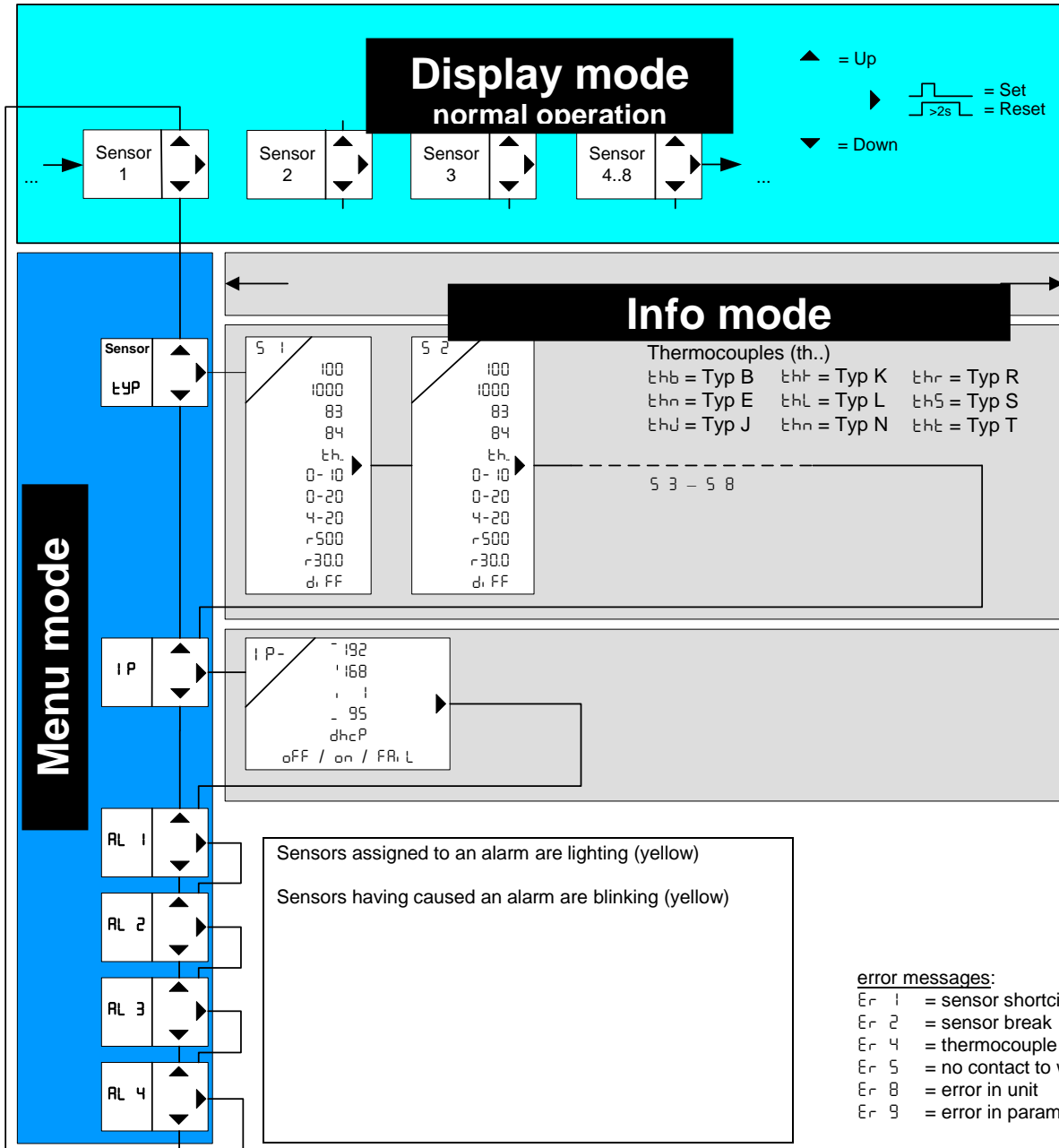

tyP	type of sensor	~ 192	1 digit of IP- address
S 1 ... S 8	sensors 1 to 8	B ' 168	2 digit of IP- address
nc	not connected	B , 10	3 digit of IP- address
100	type Pt 100	- 95	4 digit of IP- address
1000	type Pt 1000	dhcP	DHCP
83	KTY 83	oFF	DHCP off
84	KTY 84	on	DHCP on
th ..	thermocouples	FRI L	DHCP missed
0- 10	voltage input 0-10 V	AL 1 ... AL 4	alarms 1 to 4
0-20	current input 0-20 mA	boot	webserver starts
4-20	current input 4-20 mA		
r500	resistance 500 Ohm		
r30.0	resistance 30 K Ohm		
d, FF	difference		
IP	IP- address		
IP-	IP- address		

8.6 Overview of commissioning

Must	Can	Overview
X		8.7 Switch on the unit
X		8.8 Connection to network and controls
X		8.9 Find the unit in the network 8.9.1 DHCP server 8.9.2 Default IP address 10.10.10.10 8.9.3 Bonjour 8.9.4 UPnP
X		8.10 Make the basic network settings
X		8.11 Sensor settings
	X	8.13 Configure the alarms
	X	8.13 Alarm email
	X	8.14 System
	X	8.15 User management/access control
	X	8.16 Logging
	X	8.17 View measurements and alarms, sensor simulation

8.7 Switching on the unit

Apply supply voltage to terminals A1 and A2,

- ⇒ Ca. 2s long, all LEDs and the digital display illuminate (**8.8.8.8**)
- ⇒ The TR800Web is now ready to operate
- ⇒ In the digital display, **boot** flashes (alternating with sensor value), the integrated webserver starts (duration ca. 1-2 minutes). After **boot** extinguishes, the unit can be addressed via its interfaces.

8.8 Connection to network and controls

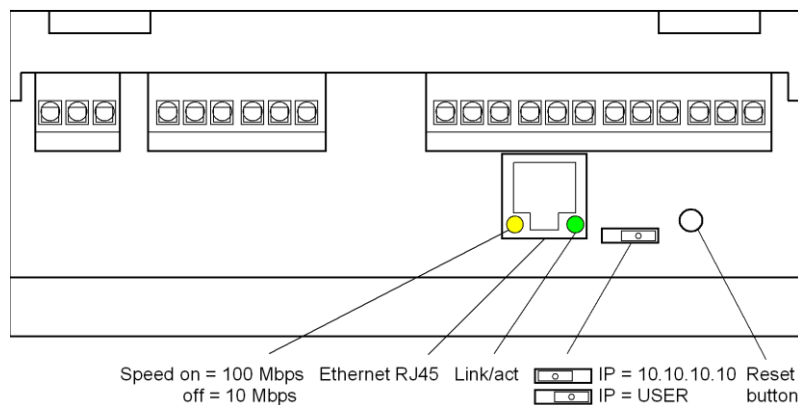
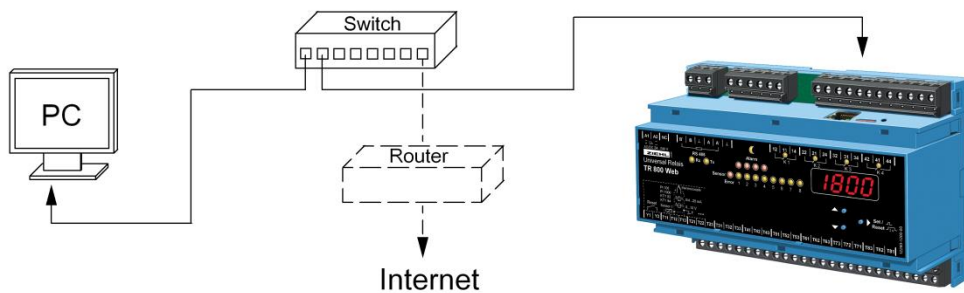

8.9 Find the unit in the network

Prerequisite: Web browser Edge, Chrome oder Firefox (tested).

The TR800Web provides four facilities to find itself in the network:

8.9.1 DHCP server

In the network, there is a DHCP server; newly added units automatically are assigned an IP address

Query of the IP address in the unit

- ⇒ Press the DOWN button 2x, then the SET button
- ⇒ IP address appears in the digital display
- ⇒ Status of DHCP query is displayed (**OFF** / **on** / **FALL**)

Start web browser and enter the IP address in the address line [Return]

- ⇒ The TR800Web homepage opens in the web browser
- ⇒ Close the login window with the OK button (without user name and without password)

If the network logon fails via DHCP, a network configuration will be performed based on zeroconf (IP = 169.254.x.x).

8.9.2 Default IP- Address 10.10.10.10

! Use this setting for configuration only.

Push slide switch to IP 10.10.10.10 (sketch Point 8.8)

- ⇒ Requires a reboot of webserver (press RESET button), in the digital display **boot** flashes (start duration ca. 1 min)

User management is deactivated, http-Port = 80 und https-Port = 443

Note: The following actions can only be performed with administrator rights.

Enter this command into your PC in the input prompt (command line):

```
route add 10.10.10.10 xxx.xxx.xxx.xxx (xxx.xxx.xxx.xxx= IP address of PC)
```

- ⇒ Route for the TR800Web

```
ping 10.10.10.10
```

- ⇒ Connection test
- ⇒ TR800Web replies

```
Reply from 10.10.10.10: Bytes=32 Time=3ms TTL=32
```

```
Reply from 10.10.10.10: Bytes=32 Time=1ms TTL=32
```

```
Ping statistic for 10.10.10.10:
```

```
Package: Sent = 4, Received = 4, Lost = 0 (0% loss),
```

- ⇒ Connection okay

Start web browser and enter the IP address (10.10.10.10) in the address line [Return]

- ⇒ The TR800Web homepage opens in the web browser
- ⇒ Close the login window with the OK button (without user name and without password)
- ⇒ Make the basic network settings
- ⇒ Push the slide switch to IP USER (sketch Point 8.8)
- ⇒ Requires a reboot of webserver (press RESET button), in the digital display **boot** flashes (start duration ca. 1-2 minutes)

Note: The settings made in the web browser under "Network" are only effective after the slide switch is switched to IP User and the unit has been rebooted (press RESET button).

8.9.4 UPnP

Available for Windows starting from Win XP
Note: not available if the http port has been switched off

Start network browser (network environment),
("Symbols for show Network UPnP devices" must be active)

Double click on the device found

- ⇒ The TR800Web homepage opens in the web browser
- ⇒ Close the login window with the OK button (without user name and without password)

8.9.5 Information about the login window

Closing the login window (click on OK button) is delayed a couple of seconds as data still needs to be transmitted in the background.

If the user admin/access control is inactive (default) the login window is not visible.
The user management/access control is always deactivated if the slide switch is set to IP=10.10.10.10 (see Points 8.8 and 8.9.2).

If the user admin/access control is active (see Point 8.15), the Username and Password must be entered.

Entry is case-sensitive.

Guest access (if activated, see Point 8.15) is made by logging in without any user name and password. Guests can only view the "Measurements" and "Sensors" web pages. It is not possible to change the parameters.

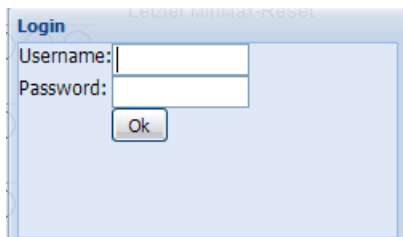

8.10 Make the basic network settings

Select "Network" in the web browser menu

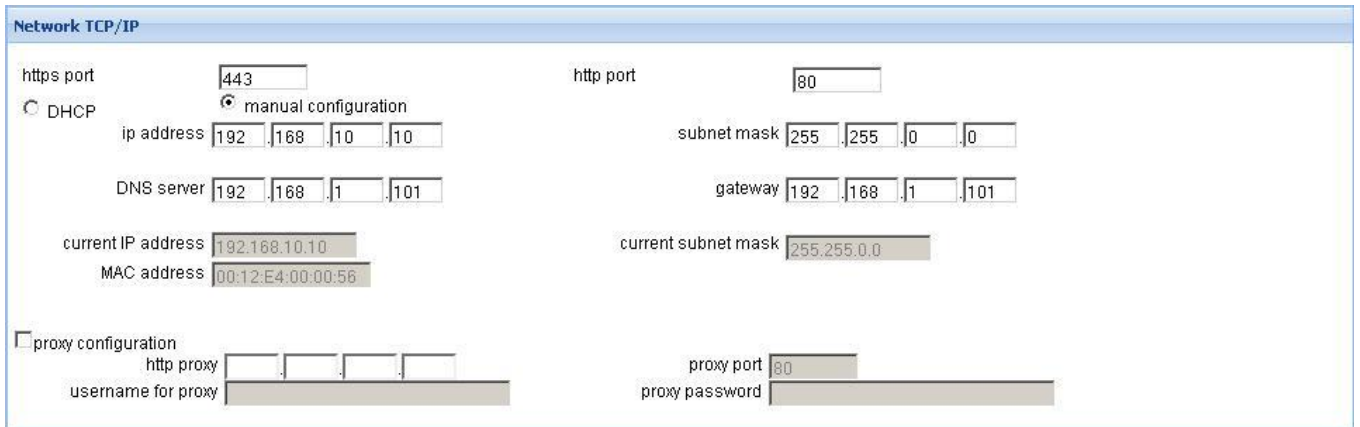
A screenshot of the 'Network TCP/IP' configuration page. It features two columns of settings. The left column includes 'https port' (443), 'DHCP' (disabled), 'ip address' (192.168.10.10), 'DNS server' (192.168.1.101), 'current IP address' (192.168.10.10), and 'MAC address' (00:12:E4:00:00:56). The right column includes 'http port' (80), 'subnet mask' (255.255.0.0), 'gateway' (192.168.1.101), and 'current subnet mask' (255.255.0.0). A 'proxy configuration' section at the bottom is currently disabled, showing fields for 'http proxy', 'username for proxy', 'proxy port' (80), and 'proxy password'.

Network TCP/IP:

You can enter the desired network parameters here.
Ask your network administrator if necessary.

Note: Switch off http with http-Port = 0.

UDP settings:

The device provides a facility to download data via the UDP protocol.

The related UDP port can be changed here.

RS485 interface:

If the device is operated on a RS485 interface, the parameters and the protocol can be selected here

Email settings:

The TR800Web provides a facility for sending an email if the alarm state changes.

Enter the access data into the corresponding boxes.

Send status e-mail:

Enter the data into the corresponding boxes.

Active services:

Services may be disabled.



8.11 Sensor settings

Select "Sensors" in the web browser menu



Make the settings for the connected sensor types here. A name can be assigned for each sensor for clear identification.

Sensor Configuration									
No.	Sensor-Name	current value	Sensor Type	Wire Compensation	Scaling			Unit	
					on	zero point	fullscale		Dec. point
1.	Temperature outside	25.4 °C	Pt 100	3-wire	<input type="checkbox"/>	0	1000	xxxx	° C
2.	Temperature room	26.6 °C	Thermo K	3-wire	<input type="checkbox"/>	0	1000	xxxx	° C
3.	Temperature winding L1	63.9 °C	Pt 100	0.0 Ω	<input type="checkbox"/>	0	1000	xxxx	° C
4.	Temperature winding L2	224.8 °C	Pt 100	0.0 Ω	<input type="checkbox"/>	0	1000	xxxx	° C
5.	Temperature winding L3	64.9 °C	Pt 100	0.0 Ω	<input type="checkbox"/>	0	1000	xxxx	° C
6.	Humidity	17.8 %	0..10 V	3-wire	<input checked="" type="checkbox"/>	0	700	xxx.x	%
7.	Sensor 7	79.0V	0..10 V	3-wire	<input checked="" type="checkbox"/>	0	800	xxx.x	V
8.	Sensor 8	26.1 °C	KTY 84	3-wire	<input checked="" type="checkbox"/>	0	600	xxx.x	° C

Box	Description
Sensor name	State a name for sensors 1 - 8
Current value	Display the measurement with the unit
Sensor type	Select the sensor type
Wire compensation	<p><u>only with Pt100 / Pt1000:</u> Select "3-wire" or choose a total wire resistance for 2-wires.</p> <p>2-wire technique wire resistance compensation: To compensate the wire resistance short-circuit the wires nearby the sensor and measure the wire resistance. We recommend to use 2 or better 3 wires for each sensor.</p> <p>With 2-wire connection and a common wire for all signals, all sensor measuring currents will be added on the common wire. Thus the value of the compensation wire resistance RK must be calculated as follows: $RK = (n+1) \times RL/2$ (RL = wire resistance of two wires, n = number of sensors)</p>
Scaling on Zero-point Full-scale Dec. point	Scaling for temperature sensors not available. Zero-point scaling Full-scale scaling Decimal point scaling
Unit	°C, °F, V, mA, Ω, kΩ, % and a freely-definable unit (box can be edited). °C and °F are available for temperature sensors.

8.12 Configuring the alarms

Alarm Configuration

Day Night now active: day

	Alarm 1 / Relay K1	Alarm 2 / Relay K2	Alarm 3 / Relay K3	Alarm 4 / Relay K4
alarm name	Alarm 1	Alarm 2	Alarm 3	Alarm 4
delay [s]	on <input type="text" value="0"/> off <input type="text" value="0"/>	on <input type="text" value="0"/> off <input type="text" value="0"/>	on <input type="text" value="0"/> off <input type="text" value="0"/>	on <input type="text" value="0"/> off <input type="text" value="0"/>
Relay	<input type="text" value="off at alarm"/>	<input type="text" value="on at alarm"/>	<input type="text" value="manual off"/>	<input type="text" value="manual on"/>
alarm on error	on <input type="radio"/> off <input checked="" type="radio"/>	on <input type="radio"/> off <input checked="" type="radio"/>	on <input type="radio"/> off <input checked="" type="radio"/>	on <input checked="" type="radio"/> off <input type="radio"/>
alarm locked	on <input type="radio"/> off <input checked="" type="radio"/>	on <input type="radio"/> off <input checked="" type="radio"/>	on <input type="radio"/> off <input checked="" type="radio"/>	on <input type="radio"/> off <input checked="" type="radio"/>
sensor no.	active Alarm ON Alarm OFF	active Alarm ON Alarm OFF	active Alarm ON Alarm OFF	active Alarm ON Alarm OFF
1.	<input type="checkbox"/> 0.056 <input type="radio"/> 1.000	<input type="checkbox"/> 1.000 <input type="radio"/> 0.970	<input type="checkbox"/> 1.000 <input type="radio"/> 0.970	<input type="checkbox"/> 1.000 <input type="radio"/> 0.970
2.	<input type="checkbox"/> 1.000 <input type="radio"/> 0.970	<input type="checkbox"/> 1.000 <input type="radio"/> 0.970	<input type="checkbox"/> 1.000 <input type="radio"/> 0.970	<input type="checkbox"/> 1.000 <input type="radio"/> 0.970
3.	<input type="checkbox"/> 100.0 <input type="radio"/> 97.0	<input type="checkbox"/> 100.0 <input type="radio"/> 97.0	<input type="checkbox"/> 100.0 <input type="radio"/> 97.0	<input type="checkbox"/> 100.0 <input type="radio"/> 97.0
4.	<input type="checkbox"/> 100.0 <input type="radio"/> 97.0	<input type="checkbox"/> 100.0 <input type="radio"/> 97.0	<input type="checkbox"/> 100.0 <input type="radio"/> 97.0	<input type="checkbox"/> 100.0 <input type="radio"/> 97.0
5.	<input type="checkbox"/> 100.0 <input type="radio"/> 97.0	<input type="checkbox"/> 100.0 <input type="radio"/> 97.0	<input type="checkbox"/> 100.0 <input type="radio"/> 97.0	<input type="checkbox"/> 100.0 <input type="radio"/> 97.0
6.	<input type="checkbox"/> 100.0 <input type="radio"/> 97.0	<input type="checkbox"/> 100.0 <input type="radio"/> 97.0	<input type="checkbox"/> 100.0 <input type="radio"/> 97.0	<input type="checkbox"/> 100.0 <input type="radio"/> 97.0
7.	<input type="checkbox"/> 100.0 <input type="radio"/> 97.0	<input type="checkbox"/> 100.0 <input type="radio"/> 97.0	<input type="checkbox"/> 100.0 <input type="radio"/> 97.0	<input type="checkbox"/> 100.0 <input type="radio"/> 97.0
8.	<input type="checkbox"/> 10.00 <input type="radio"/> 9.69	<input type="checkbox"/> 10.00 <input type="radio"/> 9.69	<input type="checkbox"/> 10.00 <input type="radio"/> 9.69	<input type="checkbox"/> 10.00 <input type="radio"/> 9.69

noAlarm Delay Alarm On Alarm Delay Alarm Off Locked Alarm

Box	Description
Day / Night	Switch the display of the alarm values for day / night operation. Definition of the switchover times in the "Time control" menu Attention: Only affects the values of "Alarm ON" and "Alarm OFF"
Alarm name	State a name for the respective alarm
Delay	on: Time (in s) during which an alarm is suppressed: off: Backshift (in s) after an alarm
Relay	on at alarm: The relay picks up during an alarm off at alarm: The relay releases during an alarm manual off: The relay is released, regardless of the alarm condition manual on: The relay is picked up, regardless of the alarm condition
Alarm on error	on: This alarm is non-delayed triggered during: device error sensor error (even if the sensors are not "active") off: This alarm is not triggered during a sensor error / device error. If a sensor triggers an alarm, and this sensor has an error, then the alarm is non-delayed reset (even if "Alarm locked" = on).
Alarm locked	on: An alarm occurring one time will not be automatically reset. Only pressing reset (close "SET/RESET" button ≥ 2s or ext. Y1/Y2 reset or break of supply voltage Us) resets the alarm. off: Alarm not locked
Sensor no.	active: Switches the alarm for this sensor on/off
	Alarm on : Value at which the device triggers an alarm
	Alarm off: Value at which the device resets an alarm

Definition of alarm values:

Value in box		Value in box	Alarm state	
Alarm on	>	Alarm off	Alarm if:	Measurement value \geq Alarm on
			Alarm off if:	Measurement value $<$ Alarm off
Alarm on	<	Alarm off	Alarm if:	Measurement value \leq Alarm on
			Alarm off if:	Measurement value $>$ Alarm off

8.13 Alarm email

In addition to an alarm message on Relay K1-K4, an email can also automatically be sent.

Alarm- E-Mail

Alarm 1 / Relay K1 Alarm 1
 Alarm 2 / Relay K2 Alarm 2
 Alarm 3 / Relay K3 Alarm 3
 Alarm 4 / Relay K4 Alarm 4

eMail on "Alarm ON" <input type="checkbox"/>	Recipient	<input type="text"/>	<input type="button" value="Add"/>
	Subject	Alarm1	
eMail on "Alarm OFF" <input type="checkbox"/>	Text	Mail Text to be sent	
	Recipient	<input type="text"/>	<input type="button" value="Add"/>
	Subject	Alarm State Changed	
	Text	Mail Text to be sent	

Box	Description
Dropdown list	Selects for which alarm (1-4) an email will be sent
Email "Alarm ON"	Email will be sent if an alarm occurs
Email "Alarm OFF"	Email will be sent if an alarm expires
Recipient	Enter email addresses (separated with a semicolon) or press "Add" button and select the addresses from the list (emails of the addresses entered in the [Users] menu)
Subject	Optional subject text
Text	Optional instructions text

8.14 System



Devicename

Device labeling

The device name appears in the uppermost line of the website after saving.

Time and Date

Use Timeserver:

last update: 2009-Apr-15 12:47:39 query interval: s

use MEZ/MESZ difference hours [h]:

2009-Apr-16 13:59:35 dd.mm.yyyy hh:mm:ss : :

The TR800Web has a real-time clock that can be synchronized with a "Timeserver" (NTP protocol, uses UDP Port 123). The server, router, proxy ... connected to the network usually provides such a function. Timeservers from the Internet can also be used (e.g. ptbtime1.ptb.de). Ask your network administrator if necessary. Alternatively, the system time can be manually set and transferred with the "Update TR 800 system time".

Save / Load Device Configuration

date	User	Comment
2009-04-01 13:20:38	Admin	Benutzermenü
2009-04-01 13:16:30	---	Benutzermenü
2009-04-01 12:58:32	---	Protokollierungsmenü
2009-04-01 12:50:16	---	Protokollierungsmenü
2009-04-01 12:49:33	---	Protokollierungsmenü
2009-04-01 12:49:26	---	Protokollierungsmenü
2009-04-01 12:47:49	---	Protokollierungsmenü

[display config as XML](#) [download config file](#)

Function	Description
Save device settings	Every change in the device can be taken over with the [Save] button; a new configuration point is automatically added. It is saved with the date, time and the user. A comment can be added to these points.
Save device settings on a PC	Activate the desired configuration ⇒ Click the link [Download config. file] ⇒ The file is downloaded to the PC
Copy device settings from PC to TR800Web	Press [Search ...] button. Choose the desired "Config. file" and press the [upload] button. ⇒ The config. file is uploaded and the configuration is taken over
Reactivate saved device settings	Activate the desired configuration ⇒ Press the [Reactivate] button ⇒ The saved configuration is taken over
Set factory settings	Press the [Set factory settings] button ⇒ The device configuration is set to the delivered condition

Using the functions "Save device settings to a PC" and "Transfer device settings from PC to TR800Web" you can very simply copy the device settings to multiple TR800Webs.



Firmware updates including the installation instructions can be downloaded from the www.ziehl.com website as needed.

8.15 User management/access control



The TR800Web has user management with access control. Stipulate the administrator, user and guest access here as required. If the user management is switched on (checkbox [active]), a password can be assigned to each user (and administrator). To do that, click on the [Change password] button. In the window that opens, enter the first and second lines for each desired password.



If the settings for the email account ("Network" menu) have been made, a test mail can be sent to each user.

Possibly occurring transmission errors are logged in the "Test mail log file".

8.16 Logging and FTP Upload

Data
Sensors
Scheduler
Logging
Network
System
Users

Logging

Data
Interval: d h min s current [show logs](#) [download logs](#) [erase log](#)

Alarms
current [show alarms](#) [download alarms](#) [erase alarm log](#)

DecSeparator: ,

FTP Upload

Upload Selection:

present data and alarms

current data memory data memory backups

current alarms memory alarms memory backups

Trigger:

log interval: d h min s

additional upload on

alarm on alarm off

[manual upload](#) [Transmission Log](#)

Target Server:

address: anonymous login "delete" before "rename"

username:

directory: password:

Logging:

Measurement data and alarms are automatically logged as specified. Data records of 1500 measurements and 500 alarm changes are logged in two ring memories. 100 ring memories are stored internally.

Recording time depending on the setting of the interval:

Interval	current ring memory recording time		100 ring memory -backups		
	1500 data records	days	days	month	year
00:00:02	0:50:00	0.0	17.4	0.6	0.0
00:00:10	4:10:00	0.2	17.4	0.6	0.0
00:00:30	12:30:00	0.5	52.1	1.7	0.1
00:01:00	25:00:00	1.0	104.2	3.4	0.3
00:03:00	75:00:00	3.1	312.5	10.3	0.9
00:05:00	125:00:00	5.2	520.8	17.1	1.4
00:30:00	750:00:00	31.3	3125.0	102.7	8.6
01:00:00	1500:00:00	62.5	6250.0	205.5	17.1

Log description:	
Content of the log files ⇒ Individual data records	Min/Max values with date/time ⇒ Date/time; Measurement values sensors 1-8; Alarm values 1-4 (sum of the sensors that triggered the alarm S1=1, S2=2...S8=128); Error number (device error)
Interval	In this time interval, the data is logged.
Checkbox ring memory Data und Alarms	Selection of the ring buffer, sorted by date.. „current“ = the last 1500 / 500 records.
DecSeparator	This character is used in the csv files.
[Display measurements] button [Display alarms] button	The selected memory of data and the alarm states can be viewed in a new window
[Delete measurements] button [Delete alarms] button	The current memory and the backups are deleted.
Download measurement data link Download alarms link	The selected memory is downloaded as a csv file

FTP Upload:

<p>With the FTP upload, depending on selection, the current data values and alarms, the current ring memory for data and alarms, and the internally stored ring memories are uploaded. There are files with the extension ". upl" uploaded and then renamed to ". csv". The filename uses the local time format. Inside the files, the selected time format is used (see System Settings). In the case of transmission problems, see the "Transmission Log" file.</p>	
Upload Selection	
present data and alarms	The file „current.csv“ will be uploaded.
Current data memory	The file „values.csv“ will be uploaded. The content consists of 1500 records (current ring memory data). file size about 100-200 kbyte.
Data memory backups	The file(s) „values.xxx.csv“ will be uploaded. xxx = Date/time in local time format.
Current alarms memory	The file „alarms.csv“ “ will be uploaded. The content consists of 500 records (current ring memory alarms). file size about 40-80 kbyte.
Alarms memory backups	The file(s) „alarms.xxx.csv“ will be uploaded. xxx = Date/time in local time format.
Trigger	
Log interval	Time between upload of „ present data and alarms“, current data memory and current alarms memory .If available, also the memory backup files are uploaded.
additional upload on „alarm on“ und „alarm off“	On change of alarm, the upload is performed.
Button [manual upload]	An upload is performed.
Link Transmission Log	Transmission Log from the last upload. Link colour: black: success; red: error.
Target Server	
address	Enter the address of the destination FTP server IP or host name. You can optionally add the port number. For example "192.168.3.3" or "192.168.3.3:2000" or "ftpservers.com"

directory	Enter the directory where the files are stored. Example: "test/test2" The indication of sub-directories with "/". There must be no "\" be used.
anonymous login	Can be activated when the FTP server allows anonymous login.
username	User name for login on the FTP server
Password	Password for the login on the FTP server
„delete“ before „rename“	This is to activate when the FTP server rename a file into an existing file is not accepted. This is in some Windows FTP servers / server program needed. See Transmission Log.

8.17 View measurements and alarms, sensor simulation

Data
Sensors
Scheduler
Logging
Network
System
Users

Sensors	Data	Unit	Min.-Value	Max.-Value	Alarm
					1 2 3 4
1. Temperature outside	23.3	°C	-31.3 <small>2009-Apr-09 09:39:40</small>	42.9 <small>2009-Apr-15 09:44:28</small>	<input type="radio"/> <input type="radio"/> <input type="radio"/> <input type="radio"/>
2. Temperature room	25.9	°C	-23.4 <small>2009-Apr-09 09:39:50</small>	33.5 <small>2009-Apr-15 16:14:50</small>	<input type="radio"/> <input type="radio"/> <input type="radio"/> <input type="radio"/>
3. Temperature winding L1	60.5	°C	16.7 <small>2009-Apr-09 09:39:40</small>	62.1 <small>2009-Apr-08 08:08:38</small>	<input type="radio"/> <input type="radio"/> <input type="radio"/> <input type="radio"/>
4. Temperature winding L2	66.8	°C	21.9 <small>2009-Apr-09 09:39:40</small>	67.6 <small>2009-Apr-07 13:48:18</small>	<input type="radio"/> <input type="radio"/> <input type="radio"/> <input type="radio"/>
5. Temperature winding L3	61.6	°C	61.4 <small>2009-Apr-15 11:58:25</small>	61.8 <small>2009-Apr-07 13:48:18</small>	<input type="radio"/> <input type="radio"/> <input type="radio"/> <input type="radio"/>
6. Humidity	41.4	V	0.0 <small>2009-Apr-09 09:40:16</small>	84.0 <small>2009-Apr-07 13:20:36</small>	<input type="radio"/> <input type="radio"/> <input type="radio"/> <input type="radio"/>
7. Sensor 7	19.0	V	0.0 <small>2009-Apr-09 11:32:26</small>	88.2 <small>2009-Apr-11 16:38:46</small>	<input type="radio"/> <input type="radio"/> <input type="radio"/> <input type="radio"/>
8. Sensor 8	27.8	°C	0.0 <small>2009-Apr-09 09:39:32</small>	40.0 <small>2009-Apr-11 15:59:42</small>	<input type="radio"/> <input type="radio"/> <input type="radio"/> <input type="radio"/>

noAlarm
 Delay Alarm On
 Alarm
 Delay Alarm Off
 Locked Alarm

Sensorsimulation

Here, all measurements can be clearly viewed with min./max. values plus the alarms. Using the sensor simulation, individual sensor values can be simulated. The simulation independently switches off after 15 minutes with no changes in the simulation value.

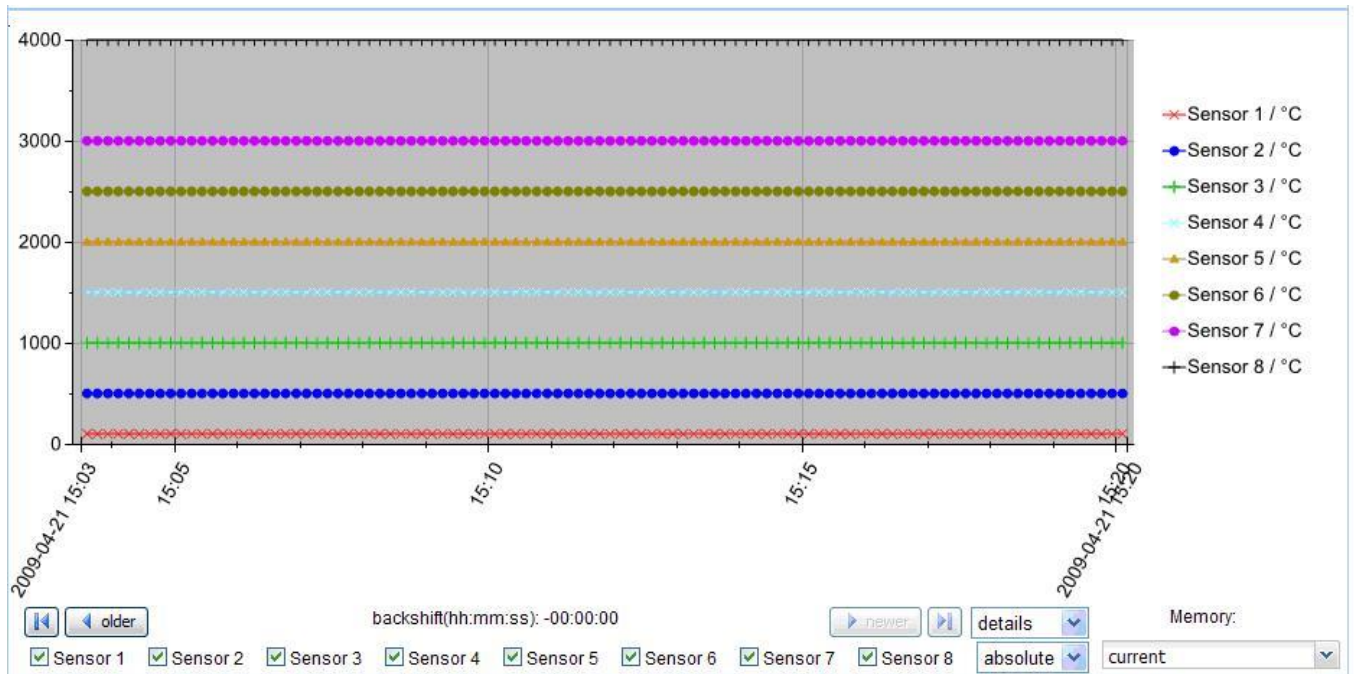

The progression of the measurements is displayed in a chart. Sensors can be flexibly displayed or hidden. The colour and the format of the line and the marker can be set.

Checkbox details: 100 logged points (see Point 8.16) are displayed in the chart. Using the [**<**older] / [**>**newer recent] buttons, one can navigate chronologically in both directions.

Complete checkbox: The entire logged area (1500 points) is shown in the chart

Absolute checkbox: Unit of the y-axis corresponds to the sensor metrics

Relative checkbox: Unit of y-axis: 0-100%

Backups Memory: Selecting the backup ring buffer, which is shown

8.18 Time-dependent control / Scheduler



scheduler

active: day
 active: night
 active: scheduled

Date / Time: Thu 2009-Apr-16 14:12:29 **now active: Day**

Night-Values

active	Day	Start	Stop	Start	Stop	Start	Stop	Start	Stop
<input type="checkbox"/>	Sun	: - :	: - :	: - :	: - :	: - :	: - :	: - :	: - :
<input type="checkbox"/>	Mon	: - :	: - :	: - :	: - :	: - :	: - :	: - :	: - :
<input type="checkbox"/>	Tue	: - :	: - :	: - :	: - :	: - :	: - :	: - :	: - :
<input type="checkbox"/>	Wed	: - :	: - :	: - :	: - :	: - :	: - :	: - :	: - :
<input type="checkbox"/>	Thu	: - :	: - :	: - :	: - :	: - :	: - :	: - :	: - :
<input type="checkbox"/>	Fri	: - :	: - :	: - :	: - :	: - :	: - :	: - :	: - :
<input type="checkbox"/>	Sat	: - :	: - :	: - :	: - :	: - :	: - :	: - :	: - :

The time control specifies which alarm values (Day or night) are active at which time.

The following settings are available:

- active: day (no time control; alarm day-values always apply)
- active: night (no time control; alarm night-values always apply)
- active: scheduled (the specified switchover times apply)

The times for the night values are entered into the table.

Up to four switch times can be set for each day of the week. To activate these times, the "active" check box for the corresponding day needs to be set.

Example for switchover times:

Specification in the web browser

active	Day	Start	Stop	Start	Stop
<input checked="" type="checkbox"/>	Sun	00 :00 - 06 :00	22 :00 - 00 :00		
<input checked="" type="checkbox"/>	Mon	00 :00 - 07 :30	21 :30 - 00 :00		

Night values are active

Su	00:00 h	-	Su.	06:00 h
Su	22:00 h	-	Mo.	07:30 h
Mo	21:30 h	-	Tu.	00:00 h

9. Ethernet protocols

Along with the http and https protocols for the web browser, the TR800Web also supports additional Ethernet protocols: UDP, Modbus, SNMP, FTP and AJAX.

9.1 UDP

The interface parameter for the UDP protocol can be viewed and changed in the web user interface [Network / UDP settings].

A detailed description of the protocol can be found in the TR800Web online help section or can be downloaded via the Internet (www.ziehl.com).

9.2 Modbus TCP

The Modbus TCP protocol is available through TCP port 502.

A detailed description can be found in the TR800Web online help section or can be downloaded via the Internet (www.ziehl.com).

9.3 SNMP

The SNMP protocol makes measurements and configuration values available (read only).

The MIB file is located in the online help of TR800Web or can be downloaded via the Internet (www.ziehl.com).

9.4 FTP Upload (Option)

Recorded measurements and alarm states can be time-controlled saved to an FTP server as a CSV file. Furthermore, it is possible to continuously transmit the current values or time controlled or event controlled (change in an alarm state).

9.5 AJAX data interface

The AJAX data interface makes data measurement and alarm data in the Ajax-compatible JSON format. The description can be found in the online help of the TR800Web.

10. RS485 interface

The RS485 interface supports two protocols: Ziehl Standard Protocol and Modbus RTU Protocol. Make the interface settings via the web browser, [Network / RS485 interface].

10.1 Ziehl Standard Protocol

A description can be found in the TR800Web online help section or can be downloaded via the Internet (www.ziehl.com).

10.2 Modbus RTU

A description can be found in the TR800Web online help section or can be downloaded via the Internet (www.ziehl.com).

11. Maintenance and Repair

ZIEHL industrie-elektronik GmbH + Co KG

Daimlerstr.13

D-74523 Schwäbisch Hall

Telephone: +49 791 504-0 Fax: +49 791 504-56

e-mail: info@ziehl.de

homepage: www.ziehl.com

12. Troubleshooting

boot appears in the digital display	
Cause	This is <u>not</u> an error. The internal webserver is starting up.
Remedy	After switching on the network, the internal webserver needs app. 1 min. until it starts. After that, the digital display extinguishes. After performing a software update, the webserver automatically reboots.
Er 5 appears in the digital display	
Cause	The internal webserver is not working correctly
Remedy	Do a reset; press the reset button on the unit (see Point 8.8) or switch off the unit and then back on. After max. 2 min, Er 5 and boot should no longer be flashing in the display.
Er 1 or Er 2 appears in the digital display	
Cause	Sensor short-circuit or sensor interruption on the TR800Web
Remedy	Check sensor on the TR800Web to see if it is electrically okay and is correctly connected.
Er 4 appears in the digital display	
Cause	A connected thermocouple is connected the wrong way around
Remedy	Check the thermocouple and connect it correctly if applicable
Er 8 appears in the digital display	
Cause	Internal device error
Remedy	Switch unit off and back on. If the error message continues to appear, the unit must be returned to the factory for repair
LED Rx and Tx constantly flash	
Cause	The unit is momentarily performing a software update
Remedy	A software update can take up to 5 min. After that, the LEDs automatically go out. If the LEDs continue to flash, an error occurred during the software update. ⇒ Switch off the unit and back on. The LEDs must go out
Displayed temperature does not match the sensor temperature	
Cause	<ul style="list-style-type: none"> ○ False measuring-unit was set ○ Error in the scaling
Remedy	Check the settings in the web user interface in [Sensors – Sensor Settings]
User name/password not known	
Remedy	See 8.9.2 Set default IP address 10.10.10.10 User management is deactivated, http-Port = 80 and https-Port = 443
e-mails are not receive	
Remedy	e-mails are not receive, if multiple recipients are used. Reason could be that one address from the e-mail server is not accepted, then the e-mail is not sent. Test: Change to the browser menu "User", enter all the recipients in an "email" field, press "Test Email" button, wait for some time (10-60 s), then check the "Test Mail Logfile".

Login window cannot be closed	
Remedy	Close the browser window and then reopen it
Data graphics, Logging, it appears a later time stamp	
Remedy	Check the date and time in the menu "System". Erase all data logs with button "erase log" in menu "Logging"

13. Technical Data

Rated supply voltage U_s	AC/DC 24 – 240 V
Tolerance	DC 20,4 - 297 V AC 20 - 264 V 50-60 Hz
Power consumption	< 4 W <13 VA
Relay output	4 x 1 changeover (CO)
Switching voltage	max. AC 415 V
Switching current	max. 5 A
Switching capacity	max. 1250 VA (ohmic load) max. 120 W at DC 24 V
UL electrical ratings: E214025	250 V ac, 5 A, resistive 240 V ac, 1/2 hp 120 V ac, 1/4 hp B 300 – pilot duty, UL 508
Nominal operational current I_e	
AC15	$I_e = 3 \text{ A}$ $U_e = 250 \text{ V}$
DC13	$I_e = 2 \text{ A}$ $U_e = 24 \text{ V}$ $I_e = 0,2 \text{ A}$ $U_e = 125 \text{ V}$ $I_e = 0,1 \text{ A}$ $U_e = 250 \text{ V}$
Recommended fuse NO	4 A time-lag or miniature circuit-breaker MCB B4
Recommended fuse NC	3,15 A time-lag
Expected contact life mechanical	3×10^7 operations
Expected contact life electrical	1×10^5 operations at AC 250 V / 6 A
Test conditions	EN 61010-1
Rated impulse voltage	4000 V
Overvoltage category	III
Pollution degree	2
Rated insulation voltage U_i	300 V
On-time	100%
Galvanic insulation / Test-voltage	U_s – relays, sensors, ethernet DC 3820 V relays – sensors, ethernet DC 3820 V sensors – ethernet DC 750 V
No galvanic insulation	RS485 – sensors – reset Y1/Y2 – S1, S2
<u>Environmental conditions</u>	
Ambient temperature range	-20 °C ... +65 °C
Storage temperature range	-20 °C ... +70 °C
Altitude	Up to 2000 m
Climatic conditions	5 – 85 % rel. humidity, no condensation
External wiring temperature range	-5 °C ... +70 °C

Thermocouples according to EN 60 584, DIN 43 710:

Type	Measuring range °C		Precision
	min	Max	
B	0	1820	±2 °C T > 300°C
E	-270	1000	±1 °C
J	-210	1200	±1 °C
K	-200	1372	±2 °C
L	-200	900	±1 °C
N	-270	1300	±2 °C
R	-50	1770	±2 °C
S	-50	1770	±2 °C
T	-270	400	±1 °C

Temperature drift	< 0,01 % / K
Measuring error of the sensor wire	+0,25 µV / Ω
Reference junction	±5 °C
Measuring time	<= 440 ms

Voltage- / Current input

	Input resistance	Maximum Input signal	Precision (from Full-Scale)	
0 – 10 V	12 kΩ	27 V	0,1 %	voltage > 20 V will affect other channels
0/4-20 mA	27 Ω	100 mA	0,5 %	Input is protected by a reversible fuse

Temperature drift	< 0,02 %/K
Measuring time	<= 40 ms

Measuring of resistance:

Precision 0,0 ... 500,0 Ω	0,2 % of measured value ± 0,5 Ω
Precision 0...30,00 kΩ	0,5 % of measured value ± 2 Ω
Sensor-current	≤0,6 mA
Measuring time	<= 220 ms

Input S1 and S2:

Maximum input voltage	30 V
Maximum input current	approx. 12 mA
Switching threshold	approx. 5 mA
Minimum pulse duration	> 25 ms
Auxiliary output voltage 18V 30mA	16-21 V max. 30 mA

Housing

Design V8, switchgear mounting	
Dimensions (W x H x D)	140 x 90 x 58 mm
Mounting height	55 mm
Wire connection, one wire	each 1 x 1,5 mm ²
Stranded wire with insulated ferrules	each 1 x 1,0 mm ²
Torque of screw	0,5 Nm (3,6 lb.in)

Protection class housing
Protection class terminal
Fitting position
Installation

IP 30
IP 20
any
Snap mounting on mounting rail 35 mm according to
EN 60 715 or with screws M 4
(2 additional bars, not included in delivery)

Weight
Subject to technical changes

app. 370 g

14. Housing design V8

Dimensions in mm

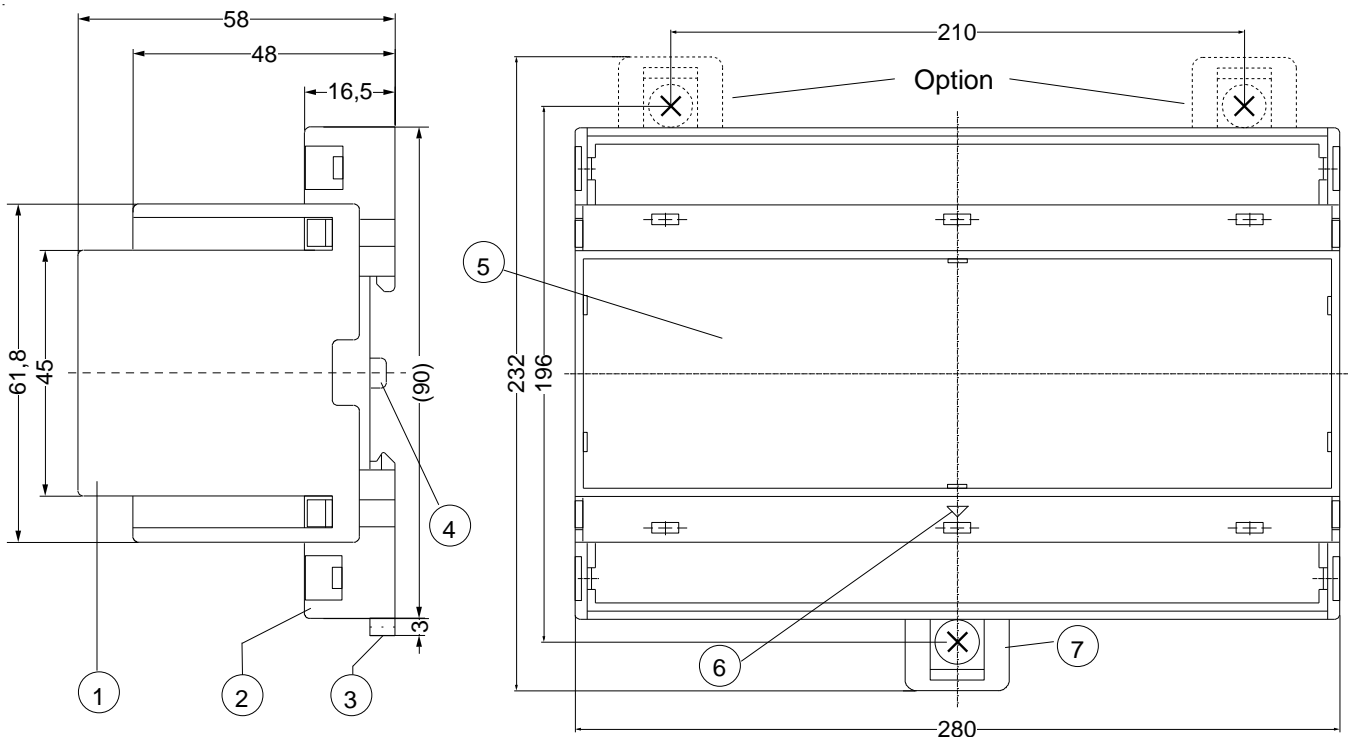

- 1 Oberteil / cover
- 2 Unterteil / base
- 3 Riegel / bar for snap mounting
- 4 Plombenlasche / latch for sealing
- 5 Frontplatteneinsatz / front panel
- 6 Kennzeichen für unten / position downward
- 7 Riegel bei Wandbefestigung mit Schrauben. Riegelbohrung \varnothing 4,2 mm / for fixing to wall with screws, \varnothing 4,2 mm.

Sie finden diese und weitere Betriebsanleitungen, soweit verfügbar auch in Englisch, auf unserer Homepage www.ziehl.de.

You find this and other operating-manuals on our homepage www.ziehl.de, as far as available also in English.