



# iMeter 8

## Advanced Power

### Quality Analyzer

# iMeter 8



**iMeter 8** is CET's Advanced PQ Analyzer designed for the compliance monitoring market as it offers un-surpassed functionality by combining Class 0.2S accuracy and advanced PQ features in a 192x192x182.4mm housing with a High-Resolution, Color Dot-Matrix LCD display. The iMeter 8 complies with such standards as IEC62053-22 Class 0.2S, IEC61000-4-30 Ed. 3.1 Class A, IEC61000-4-15, IEC61000-4-7, EN50160, IEEE Std 519-2022 as well as IEC61850 for Substation Automation. Further, it offers a large logging capacity with 8GB of on-board memory, extensive I/O, multiple Time Sync. methods, 2x100BaseT Ethernet and 2xRS-485 ports. In addition, it optionally provides 2xAO and 2xAI for different applications. These features likely make the iMeter 8 one of the most advanced PQ Analyzer for an intelligent Power Quality Monitoring System.

## Typical Applications

- PQ monitoring at HV, MV and LV Utility Substations
- Data Centers, Semiconductor Fabs, Heavy Industries
- 7x24 Automated Manufacturing Facilities
- Dips, Swells, Interruptions, Transients, Flickers and Harmonics Monitoring
- Mains and Critical Feeder Monitoring
- IEC61850 support for Substation Automation and Smart Grid
- Retrofit applications with Split-Core Current Probe (SCCP)

## Basic Features

- IEC62053-22 Class 0.2S kWh metering with Multi-Tariff TOU
- True RMS @ 1024 samples/cycle sampling
- 8GB on-board log memory
- 7" High-Resolution Color Dot-Matrix Display @ 800x480
- Time Sync. via SNTP, IEEE 1588 (PTP), IRIG-B or GPS 1PPS output
- 256 Standard Setpoints and 16 High-Speed Setpoints
- Dual 100BaseT Ethernet and two RS-485 ports

## Display & Web Servers

- True RMS Real-time, Harmonics, Power and Energy Measurements
- Demands and Multi-Tariff TOU
- Max. & Min. Logs
- Sequence & Unbalance
- Real-time WF Capture of 3-phase Voltages and Currents
- Event Waveforms, RMS Recording and ITIC/SEMI F47 Curves
- Harmonics & Interharmonics Histogram and Phasor Diagrams
- Device and SOE Logs, PQ Counters, Audit Logs and I/O Status
- Device Configuration and Diagnostics

## Metering

### Basic Measurements (1-second update)

- 3-phase U, I, P, Q, S, and PF as well as U4, I4 and I5
- kWh, kvarh Import/Export/Net/Total and kVAh Total
- Frequency

### High-Speed Measurements

- 3-phase U, I, P, Q, S, and PF as well as U4, I4 and I5 @ ½ cycle
- Frequency @ 1 cycle

### Demands

- Present and Predicted Demand for 3-phase U, I, P, Q, S, and PF as well as U4, I4, I5, Frequency
- Present Demand of 4-phase U & I THD/TOHD/TEHD, 4-phase Current K-Factor, U/I Unbalance, Over & Under Deviation of Voltage and Frequency, 4-phase Fundamental Current
- Max./Min. values per Demand Interval
- Maximum Demands for This Month & Last Month (or Since Last Reset & Before Last Reset)
- Demand Synchronization with DI

# Advanced Power

## Multi-Tariff TOU Capability

- Two independent sets of TOU Schedules, each supporting
  - Up to 12 Seasons
  - 90 Holidays or Alternate Days and 3 Weekdays
  - 20 Daily Profiles, each with 12 Periods in 15-minute interval
  - 8 Tariffs, each providing the following information:
    - kWh/kvarh Import/Export and kVAh
    - P & Q Import/Export Maximum Demands with timestamp
    - Register rollover at 100,000,000,000.000 kXh
- Switching between two TOU schedules manually or according to pre-programmed time
- 12 Historical Logs for Energy and Maximum Demand

## Power Quality Features

- IEC61000-4-30 Ed. 3.1 Class A Certified
- IEC61000-4-15, IEC61000-4-7 Compliance
- 2kHz to 150kHz Conducted Emission Measurements
- Disturbance Direction Indicator
- Disturbance Waveform Recording, RMS Recording
- EN50160 and IEEE Std 519-2022 Reporting
- Fault Capture up to 2,000V peak to peak
- Waveform Recording in COMTRADE and PQDIF file format (Compatible with the PQ View software)

## Power Quality Metering

### PQ Parameters as per IEC61000-4-30 Ed. 3.1 Class A Certified

- Power Frequency
- Magnitude of the Supply Voltage and Current
- Flicker
- Supply Voltage Dips, Swells and Interruptions
- Supply Voltage Unbalance and Current Unbalance
- Mains Signaling Voltage on the Supply Voltage
- Rapid Voltage Changes
- Measurement of Over Deviation and Under Deviation Parameters
- Harmonics and Interharmonics for Voltage and Current
- 2kHz to 150kHz Conducted Emission Measurements

### Harmonic and Interharmonic Measurements

- K-Factor for Current, Crest Factor for Current and Voltage
- U and I THD, TOHD, TEHD, TIHD, TOIHD, TEIHD and TH (RMS)
- U and I Individual Harmonics (%HD and RMS) from 2<sup>nd</sup> to 63<sup>rd</sup> #
- U and I Individual Interharmonics (%IHD and RMS) from 1<sup>st</sup> to 63<sup>rd</sup> #
- Total Harmonic P, Q, S and PF
- Harmonic P, Q, S and PF from 2<sup>nd</sup> to 63<sup>rd</sup> in RMS
- Harmonic Phase Angle from 2<sup>nd</sup> to 63<sup>rd</sup> #
- U and I DC Components
- Total Harmonic kWh, kvarh Import/Export/Net/Total
- Total Harmonic kWh, kvarh Import/Export from 2<sup>nd</sup> to 63<sup>rd</sup>

#%HD and %IHD can be configured as % of Fundamental, % of U/I nominal or % of RMS

### Dips, Swells, Interruptions Recording

- Dips, Swells & Interruptions detection @ 10ms (½ cycle at 50Hz)
- Trigger for DO, SOE Log, DR, WFR, DWR, RMSR, iTrigger and Alarm Email
- Display of Event specific WFR, DWR and/or RMSR as well as the associated ITIC/SEMI F47 plot on the Front Panel and Web Interface
- ITIC/SEMI F47 Alarm trigger for DO and iTrigger upon the detection of Dips, Swells and Interruptions that are outside of the respective tolerance curves

### Sequence and Unbalance

- Zero, Positive and Negative Sequence Components
- U and I Unbalance based on Zero and Negative Sequence Components

### Conducted Emissions in the 2kHz to 150kHz Range

- Real-time amplitude (150/180-Cycle) and the Max., Min., Avg. and CP95 (in 1-minute interval) for a total of 106 frequency segments for the 2kHz-9kHz ( $U_{rms}$  and  $I_{rms}$ ) and 9kHz -150kHz ( $U_{rms}$ ) range
- Daily Heat Map display on the Web Interface for the Max., Min., Avg. and 95<sup>th</sup> percentile values

### Transients Recording

- Transients capture as short as 20us @ 50Hz or 16.67us @ 60Hz at 1024 samples for sub-cycle disturbance such as capacitor switching and resonance phenomena
- Display of Event specific WFR, DWR and/or RMSR on the Front Panel and Web Interface

### Rapid Voltage Changes (RVC)

- Detection of a quick transition in RMS voltage between two steady-state voltage conditions

### Inrush Current Monitoring

- Monitoring of the ½ cycle RMS Current and capturing of the Current waveforms associated with events such as motor starting and transformer being energized

### Disturbance Direction Indicator

- Determine if a Dip/Swell/Interruption Event is located upstream or downstream
- Pinpoint if the cause of the event is external or internal

### PQ Event Counters

- Dips, Swells, Interruptions, Transients, Rapid Voltage Changes, Inrush Current, Mains Signalling Voltages and Total PQ Event Counters

### Real-Time Waveform Capture (WFC) and Waveform Recorder (WFR)

- Real-time WFC @ 128 samples/cycle x 4 cycles via Front Panel and Web Interface
- WFR with maximum 128 entries
- Simultaneous capture of 4-phase Voltage and Current Inputs
- No. of Cycles x Samples/Cycles with programmable pre-fault cycles: (40-400)x1024, (40-800)x512, (40-1600)x256, (40-3200)x128
- Scheduled WFR with maximum repetition of 10,000 times and programmable schedule from 1 to 1440 mins
- COMTRADE file format, downloadable from the on-board Web Server or FTP Server

### Disturbance Waveform Recorder (DWR)

- 128 entries
- Simultaneous recording of all Voltage (U1-U4) and Current (I1-I4) Inputs
  - Initial Fault: 35 cycles @ 512 samples/cycle
  - Extended Fault: Up to 150 cycles @ 16 samples/cycle
  - Steady State: Up to 360s of 1-cycle absolute peak values
  - Post Fault: 15 cycles @ 512 samples/cycle

### RMS Recorder (RMSR)

- 128 entries
- 16 parameters max., selectable U, I, P, Q, S, PF, Freq., Freq. Deviation
- Recording Interval from 0.5 to 60 cycles
- Recording Depth @ 7200 samples per parameter
- Configurable pre-fault samples from 100 to 500
- 72 seconds of ½ cycle RMS Recording @ 50Hz or 60 seconds @ 60Hz
- Display of U & I RMSR triggered by events on the Web Interface

# Quality Analyzer

## Data and Event Recorders

### Non-Volatile Log Memory

- 8GB on-board non-volatile Log Memory

### Interval Energy Recorder (IER) and Accumulative Energy Recorder (AER)

- Both IER Log and AER Log support recording of Total RMS kWh, kvarh Import/Export/Total/Net and kVAh, Total Fundamental and Total Harmonic kWh, kvarh Import/Export
- Recording Interval from 1 to 65535 minutes
- Maximum Recording Depth @ 65535 records
- Support FIFO and Stop-When-Full modes

### Device Log

- 1024 FIFO entries time-stamped to  $\pm 1$ ms resolution
- Power On/Off Records, Setup changes, Time Sync., Device Operations and Self-diagnostics

### Data Recorder (DR) Log

- 8 DR Logs capable of recording up to 64 parameters each
- Recording Interval from 1s to 40 days
- Programmable sources such as
- RMS/Fundamental/Harmonic/Interharmonic Measurements, Demands, Deviations, MSV, Unbalances and Flicker
- Configurable Recording Offset
- Support FIFO or Stop-When-Full recording modes

### Statistical Data Recorder (SDR)

- 16 SDR Logs of maximum 64 parameters each
- Recording of the Max., Min., Avg. and CP95 for Real-time Measurements including U, I, P, Q, S, PF, Freq., Power, PF, Harmonics, Deviations and Unbalances
- Recording interval from 0 minute to 60 minutes
- 30 days @ 1-minute, 300 days @ 10-minute, 450-day @ 15-minute
- PQDIF file format, downloadable from the on-board FTP Server
- Support FIFO or Stop-When-Full mode

### Max./Min. Recorder (MMR)

- 4 Max./Min. Recorders of 20 parameters each
- RMS/Fundamental/Harmonic/Interharmonic Measurements, Demands, Deviations, Unbalances and Flicker
- Two transfer modes:
  - Manual: Max./Min. Since Last Reset & Before Last Reset
  - Auto: Max./Min. of This Month & Last Month

### SOE Log

- 1024 FIFO events time-stamped to  $\pm 1$ ms resolution
- Setpoint events, I/O operations, Dips, Swells, Interruptions, Transients, Rapid Voltage Changes, Inrush Current, Mains Signalling Voltages, Motor Start, iTrigger, etc.

- Record the time and characteristic data for Setpoints and PQ events

### Audit Logs

- Display of Log In/Out events, View/Export/Clear Audit Logs on the Web Interface for Auditor Account
- Store up to 2048 Audit Logs in non-volatile memory
- Support FIFO or Stop-When-Full recording modes

### iTrigger

- Cross trigger DO, SOE Log, WFR, DWR, RMSR and Alarm Email with other iMeter devices within the same local area network (LAN)
- Programmable via Web Interface or Communications

### IEEE Std 519-2022 Report

- 365 Daily Reports for statistical evaluations on Voltage and Current Harmonics based on 99<sup>th</sup> percentile very short time (3s) values
- 52 Weekly Reports for statistical evaluations on Voltage Harmonics (95<sup>th</sup> percentile) and Current Harmonics (95<sup>th</sup> and 99<sup>th</sup> percentile) short time (10 min) values
- Configurable Report Mode, PCC Voltage, Max. Short Circuit Current, etc.

## Time Synchronization

- Battery-backed Real-time clock @ 6ppm ( $\leq 0.5$ s/day)
- Time Sync. via Modbus RTU/TCP, SNTP, IEEE1588 (PTP)
- Optional GPS/IRIG-B Input

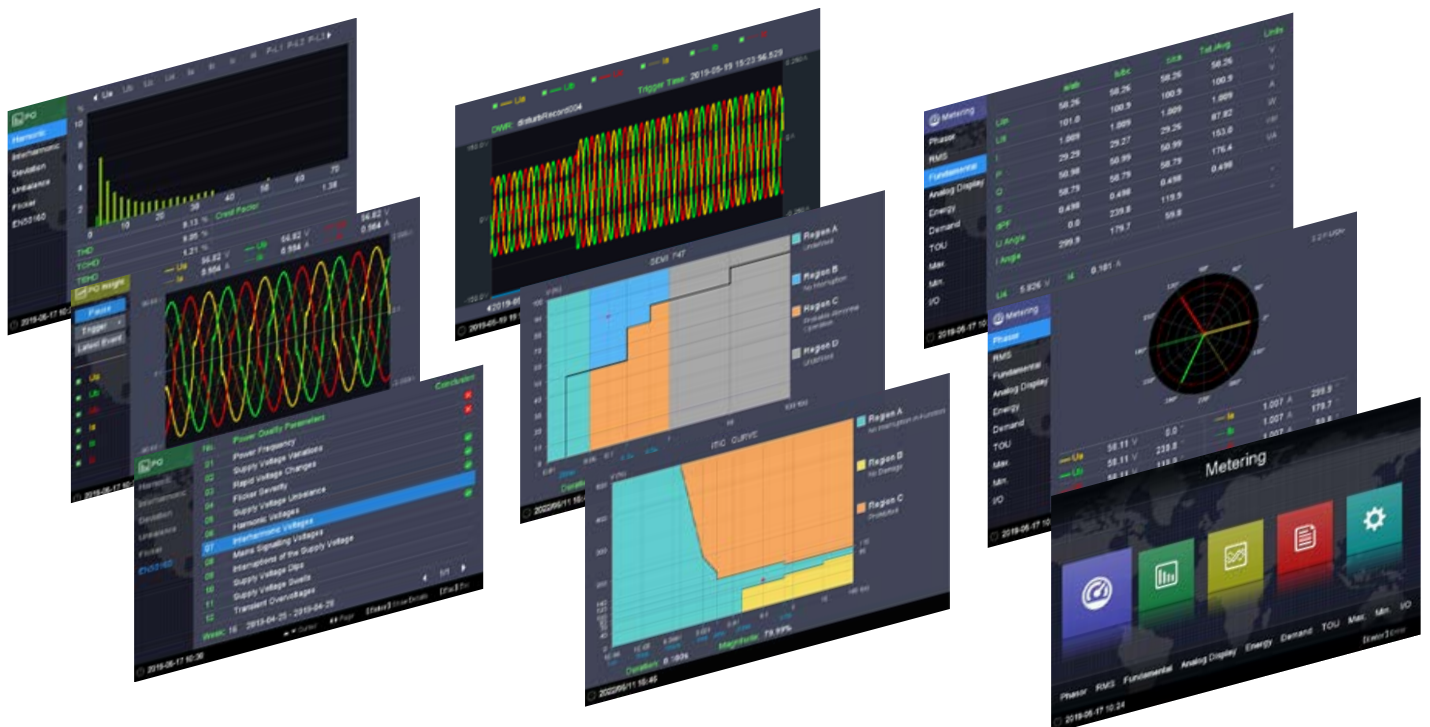

# iMeter 8



## Setpoints

### PQ Setpoints

- Transients, Dips, Swells, Interruptions, ITIC Alarm and SEMI F47 Alarm
- Rapid Voltage Changes
- Inrush Current
- Trigger DO, DR, SOE Log, WFR, DWR, RMSR, iTrigger and Alarm Email

### Control Setpoints

- 256 standard and 16 High-Speed Setpoints
- Extensive monitoring sources including U, I, P, Q, S, Demand, Harmonics, Unbalances, Deviations, Flickers, Phase Reversal/Loss, AI, etc.
- Configurable thresholds and time delays
- Trigger DO, DR, SOE Log, WFR, DWR, RMSR, iTrigger and Alarm Email

### Motor Start Setpoints

- Monitoring motor startup procedure with recording of Max. Starting Current, Minimum Voltage and Duration
- Trigger DO, SOE Log, WFR, DWR, RMSR, iTrigger and Alarm Email

### Digital Input Setpoints

- Provides control output actions in response to changes in Digital Input status
- Trigger DO, DR, SOE Log, WFR, DWR, RMSR, iTrigger and Alarm Email

## Inputs and Outputs

### Digital Inputs

- Standard 8 or optional 16 channels
- Standard volt free dry contact with 24VDC Internal Excitation
- Optional 110VAC/DC or 220VAC/DC External Excitation
- 1000Hz sampling for status monitoring with programmable debounce
- Pulse counting with programmable weight for each channel for collecting WAGES (Water, Air, Gas, Electricity, Steam) information
- Demand Synchronization and Tariff Switch based on DI Status

### Digital Outputs

- Standard 3 or optional 7 channels Form A and 1 channel Form C Mechanical Relays for general purpose control or alarming
- Optional 2 or 4 SS Relays for Energy pulsing applications

### Analog Inputs (Optional)

- Two channels 0/4-20mA DC input with programmable zero and full scales that can be used to measure external transducer signal

### Analog Output (Optional)

- One or two channels 0/4-20mA DC output with programmable zero and full scales

## Communications

### Ethernet Ports (P1, P2)

- Dual 10/100BaseT Ethernet Ports with RJ45 connector
- Protocols supported: Modbus TCP, HTTPS, SNMP, SMTPS, FTP and IEC61850
- Built-in password protected Web Server with multiple user accounts and pre-defined roles for easy data viewing, setup configuration and firmware upgrade
- Simultaneous client connections for 12xModbus TCP & 12xIEC61850

### RS-485

- Dual optically isolated RS-485 port with baud rate from 1.2 to 38.4kbps
- Support Modbus RTU and Ethernet Gateway

## System Integration

### PecStar® iEMS

- The iMeter 8 is supported by CET's PecStar® iEMS
- In addition, the iMeter 8 can be easily integrated into other 3<sup>rd</sup> party systems because it supports of multiple communications ports as well as different industry standard protocols such as Modbus and IEC61850

### DiagSys

- Display of Real-time Measurements, PQ Events, Waveforms and Statistical Trend Charts
- Export of IER, AER and SDR Logs as well as EN50160 Reports
- Generation and Export of Self-defined PQ Analysis Reports

### 3<sup>rd</sup> Party System Integration

- Easy integration into Substation Automation or Utility SCADA systems via Modbus RTU, Modbus TCP or IEC61850
- The on-board, password-protected Web Server provides user-friendly access to its data and supports the configuration for most Setup parameters via a web browser without the use of proprietary software
- The on-board, password protected FTP Server allows Excel files for the logged C.E. Measurement data, IEEE Std 519-2022 Daily and Weekly reports and waveform records in COMTRADE format as well as PQDIF files to be downloaded without any special software. The downloaded files can be subsequently viewed using software that supports the industry standard PQDIF and COMTRADE file formats.

# Accuracy

Parameters	Accuracy	Resolution
Voltage (U)	±0.1%	0.001V
I1, I2, I3	±0.1%	0.001A
	SCCPA Option: ±0.1%+Error of SCCP	
I4	±0.1%	0.001kX
I5	±0.5%	
P, Q, S	±0.2%	0.001kX
	SCCPA Option: ±0.5%	
kWh, kVAh	IEC62053-22 Class 0.2S	0.1kXh
	SCCPA Option: IEC62053-21 Class 1	
kvarh	IEC62053-24 Class 0.5S IEC62053-23 Class 2	0.1kvarh
	SCCPA Option: IEC62053-24 Class 1	
PF	±0.2%	0.001
	SCCPA Option: ±0.5%	
Frequency	±0.003Hz	0.001Hz
Harmonics	IEC61000-4-7 Class I	0.001
Phase Angle	±0.2°	0.1°
	SCCPA Option: ±0.2°+ Phase Error of SCCP	
U Unbalance	±0.1%	0.01%
I Unbalance	±0.5%	0.01%
Pst, Plt	IEC61000-4-15 Class F1	0.01%

## Power Supply (L+, N-)

Standard	95-250VAC/VDC ±10%, 47-440Hz
Optional	20-60VDC
Burden	< 12W
Oversvoltage Category	OVC III 300V

## Digital Inputs ( DIC, DI1 to DI8 or DI16)

Standard	Dry contact, 24VDC internally wetted
Optional	110V/220V AC/DC externally wetted
Sampling	1000Hz
Hysteresis	1ms minimum

## Form A Relay Outputs (DO1 to DO3 or optional DO1 to DO7)

Type	Form A Mechanical Relay
Loading	5A @ 250VAC/30VDC

## Form C Relay Outputs (Alarm 1, 2, 3)

Type	Form C Mechanical Relay
Loading	8A @ 250VAC/24VDC

## Pulse Outputs (E1+, E1-, E2+, E2-, E3+, E3-, E4+, E4-)

Type	Form A Solid State Relay
Isolation	Optical
Max. Load Voltage	30VDC
Max. Forward Current	4mA

## Optional Analog Input (AI1+, AI1-, AI2+, AI2-)

Type	0-20/4-20 mA DC
Overload	24 mA maximum

## Optional Analog Output (AO1+, AO1-, AO2+, AO2-)

Type	0-20/4-20 mA DC
Loading	500Ω maximum
Overload	24 mA maximum

## Environmental Conditions

Operating Temperature	-25°C to 70°C
Storage Temperature	-40°C to 85°C
Humidity	5% to 95% non-condensing
Atmospheric Pressure	63 kPa to 110 kPa
Pollution Degree	2

## Mechanical Characteristics

Panel Cutout	186x186mm
Unit Dimensions	192x192x182.4mm
IP Rating	52

# Standards of Compliance

## Safety Requirements

CE LVD 2014/35/EU	EN61010-1: 2010 EN61010-2-030: 2010
Electrical Safety in Low Voltage Distribution Systems up to 1000Vac and 1500Vdc	IEC61557-12: 2018 (PMD)
Insulation AC Voltage: 2kV @ 1 minute Insulation Resistance: >100MΩ Impulse Voltage: 6kV, 1.2/50μs	IEC62052-11: 2003 IEC62053-22: 2003 EN61010-1: 2010

# Technical Specifications

## Voltage Inputs (V1, V2, V3, VN, V4, V4N)

Standard (Un)	400ULN/690ULL +20%	
Range	1% to 200% Un for 400ULN nominal	
Overload	2xUn continuous, 4xUn for 1s	
Burden	< 0.5VA/per phase	
PT Ratio	Primary	1-1,000,000V
	Secondary	1-1,500V
	V4 Primary	1-1,000,000V
	V4 Secondary	1-1,500V
Measurement Category	CAT III 1000V	
Frequency	40Hz-60Hz @ 50Hz, 48Hz-72Hz @ 60Hz	

## Current Inputs (I11, I12, I21, I22, I31, I32, I41, I42, I51, I52)

Standard (In)	5A (Standard), 1A (Optional)	
Range	1% to 400% In	
Starting Current	0.1% In	
Overload	4xIn continuous, 20xIn for 1s	
Burden	< 0.5VA/per phase @ 5A	
	< 0.1VA/per phase @ 1A	
SCCP Options	SCCP-50A-500mV	5A/50A (In/Imax), max. 500mV Output
	SCCP-200A-200mV	20A/200A (In/Imax), max. 200mV Output
	SCCP-500A-500mV	500A Imax, max. 500mV Output
	SCCP-5000A-500mV	Selectable 500A/5000A (Imax) Rogowski Coil, max. 500mV Output
CT Ratio	Primary	1-30,000A
	Secondary	1-50A
	I4 Primary	1-30,000A
	I4 Secondary	1-50A

# EMC Compatibility

CE EMC Directive 2014/30/EU (EN61326: 2013)

Immunity (EN50082-2)	
Electrostatic Discharge	EN61000-4-2: 2009
Radiated Fields	EN61000-4-3: 2006 +A1: 2008 +A2: 2010
Fast Transients	EN61000-4-4: 2012
Surges	EN61000-4-5: 2014 +A1: 2017
Conducted Disturbances	EN61000-4-6: 2014
Magnetic Fields	EN61000-4-8: 2010
Voltage Dips and Interruptions	EN61000-4-11: 2004+A1: 2017
Ring Wave	EN61000-4-12: 2017

Emission (EN50081-2)	
Limits and Methods of Measurement of Electromagnetic Disturbance Characteristics of Industrial, Scientific and Medical (ISM) Radio-Frequency Equipment	EN55011: 2016
Limits and Methods of Measurement of Radio Disturbance Characteristics of Information Technology Equipment	EN55032: 2015
Limits for Harmonic Current Emissions for Equipment with Rated Current $\leq 16$ A	EN61000-3-2: 2014
Limitation of Voltage Fluctuations and Flicker in Low-Voltage Supply Systems for Equipment with Rated Current $\leq 16$ A	EN61000-3-3: 2013
Emission Standard for Industrial Environments	EN61000-6-4: 2007 +A1: 2011

Mechanical Tests		
Vibration Test	Response	IEC255-2-1: 1989
	Endurance	IEC255-2-1: 1989
Shock Test	Response	IEC255-2-2
	Endurance	IEC255-2-2
Bump Test		IEC255-2-2

Power Quality	
Voltage Characteristics of Electricity Supplied by Public Distribution Systems	EN50160: 2010
General Guide on Harmonic and Interharmonic Measurements and Instrumentation, for Power Supply Systems and Equipment Connected Thereto	IEC61000-4-7: 2009
Flicker Meter - Functional and Design Specifications	IEC61000-4-15: 2010
Testing and Measurement Techniques-Power Quality Measurement Methods	IEC61000-4-30: 2021 Ed. 3.1 Class A Certified
Power Quality Measurement in Power Supply Systems-Part 2: Functional Tests and Uncertainty Requirements	IEC62586-2: 2021 Ed.2.1
Harmonic Control in Electrical Power systems	IEEE Std 519-2022

# Device Dimensions

Unit: mm

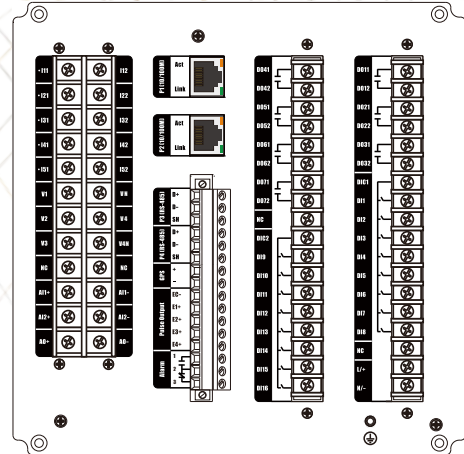

16xDI+8xDO+2xAI+1xAO

Rear Panel

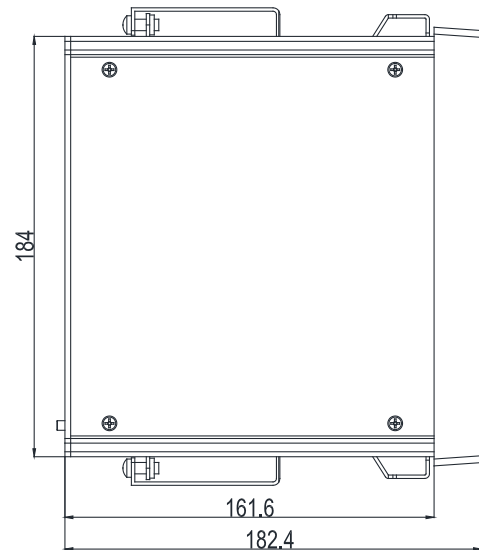

Side view

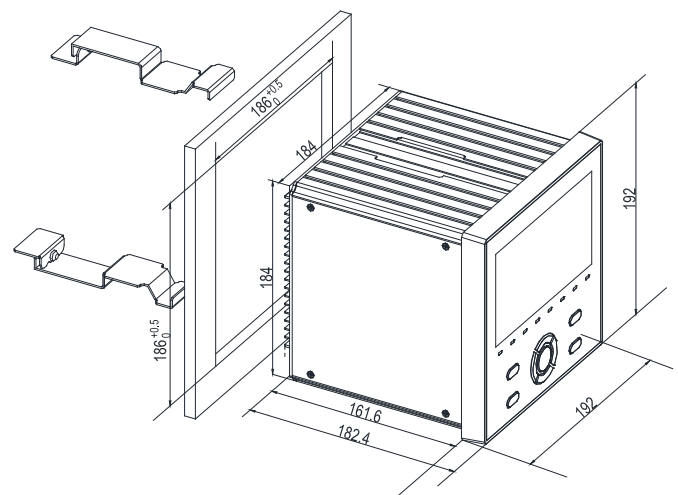

Installation

# Ordering Guide

Product Code											Description	
iMeter 8 Advanced Power Quality Analyzer												
Basic Feature	A										1024 samples/cycle, 8GB On-Board Memory, IEC61000-4-30 Ed. 3.1 Class A Certified	
	B**										1024 samples/cycle, 8GB On-Board Memory, IEC61000-4-30 Ed. 3.1 Class A Certified with 2-150kHz C.E. Measurement	
Input Current	5										5A	
	1										1A	
	SCCPA <sup>^</sup>										SCCP Option for use with CT Clamps with max. 500mV output	
Input Voltage	9										400ULN/690ULL + 20%	
Power Supply	2										95-250VAC/DC ±10%, 47-440Hz	
	3**										20-60VDC	
System Frequency	5										50Hz	
	6										60Hz	
I/O	A										8xDI + 4xDO + 4xSS Pulse Outputs	
	B**										8xDI + 4xDO + 2xAI + 1xAO + 4xSS Pulse Outputs	
	C*										16xDI + 8xDO + 4xSS Pulse Outputs	
	D**										8xDI + 4xDO + 2xAI + 2xAO + 2xSS Pulse Outputs	
DI Excitation	N										Dry Contact (@24VDC Self-Excitation)	
	1 <sup>#</sup>										110V AC/DC External Excitation	
	2 <sup>#</sup>										220V AC/DC External Excitation	
Communications	A										2x100BaseT + 2xRS-485	
Time Sync.	A										GPS, IRIG-B	
Display Language	E										English	
iMeter 8	-	A	5	9	2	5	A	N	A	A	E	iMeter 8-A5925ANAAE (Standard Model)

\* Additional charges apply.

- The I/O options "B" and "D" are not supported when the Basic Feature option "B" is selected.

<sup>^</sup> The SCCPA option is compatible with the SCCP models listed in the "SCCP Option" sheet. This option does not come with any Current Clamp. Please refer to the "SCCP Option" sheet for more information and order the desired model and quantity as a separate item.

# The DI Excitation options "1" and "2" are not supported when the Power Supply option "3" with 20-60VDC is selected.

## Optional SCCPs

				
Model No.	PMC-SCCP-50A-500mV-B-A-B	PMC-SCCP-200A-200mV-B-B-B	PMC-SCCP-500A-500mV-B-B-B	* PMC-SCCP-5kA-500mV-B-C-C-371/254/150/100
Measurement Range	5A (50A I <sub>max</sub> )	20A/200A (200A I <sub>max</sub> )	500A (500A I <sub>max</sub> )	500A/5000A Rogowski Coil (5000A I <sub>max</sub> )
Max. Allowable Current	50A	260A	500A	10,000A
Output Voltage	AC 10mV/A (Max. 500mV)	AC 10mV/A @ 20A AC 1mV/A @ 200A (Max. 200mV)	AC 1mV/A (Max. 500mV)	AC 1mV/A @ 500A AC 0.1mV/A @ 5000A (Max. 500mV)
Accuracy	±0.3% rdg. ±0.02% f.s.	±0.3% rdg. ±0.02% f.s.	±0.3% rdg. ±0.02% f.s.	±2.0% rdg. (1% - 200%) I <sub>n</sub>
Protection	CAT III 300V	CAT III 600V	CAT III 600V	CAT III 1000V CAT IV 600V
Diameter	15mm	24mm	50mm	371/254/150/100mm
Cable Length	3m	3m	3m	3m
Termination	BNC	BNC	BNC	BNC

\* The Rogowski Coil SCCP comes with an external Universal Power Supply and an integrator.

Your Local Representative

Email: [sales@cet-global.com](mailto:sales@cet-global.com)

Website: [www.cet-global.com](http://www.cet-global.com)

Copyright © CET Inc. All rights reserved.

V.00 29.05.2023