

PMC-350-C

Three-Phase LoRaWAN DIN

Energy Meter

User Manual

Version: V1.1A
August 19, 2022

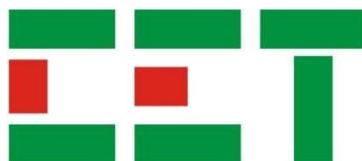

This manual may not be reproduced in whole or in part by any means without the express written permission from CET Inc. (CET).

The information contained in this manual is believed to be accurate at the time of publication; however, CET assumes no responsibility for any errors which may appear here and reserves the right to make changes without notice. Please consult CET or your local representative for the latest product specifications.

Standards Compliance



DANGER

This symbol indicates the presence of danger that may result in severe injury or death and permanent equipment damage if proper precautions are not taken during the installation, operation or maintenance of the device.



CAUTION

This symbol indicates the potential of personal injury or equipment damage if proper precautions are not taken during the installation, operation or maintenance of the device.



DANGER

Failure to observe the following instructions may result in severe injury or death and/or equipment damage.

- Installation, operation and maintenance of the meter should only be performed by qualified, competent personnel that have the appropriate training and experience with high voltage and current devices. The meter must be installed in accordance with all local and national electrical codes.
- Ensure that all incoming AC power and other power sources are turned OFF before performing any work on the meter.
- Before connecting the meter to the power source, check the label on top of the meter to ensure that it is equipped with the appropriate power supply, and the correct voltage and current input specifications for your application.
- During normal operation of the meter, hazardous voltages are present on its terminal strips and throughout the connected potential transformers (PT) and current transformers (CT). PT and CT secondary circuits are capable of generating lethal voltages and currents with their primary circuits energized. Follow standard safety precautions while performing any installation or service work (i.e. removing PT fuses, shorting CT secondaries, etc).
- Do not use the meter for primary protection functions where failure of the device can cause fire, injury or death. The meter should only be used for shadow protection if needed.
- Under no circumstances should the meter be connected to a power source if it is damaged.
- To prevent potential fire or shock hazard, do not expose the meter to rain or moisture.
- Setup procedures must be performed only by qualified personnel familiar with the instrument and its associated electrical equipment.
- **DO NOT** open the instrument under any circumstances.



Limited warranty

- CET offers the customer a minimum of 12-month functional warranty on the meter for faulty parts or workmanship from the date of dispatch from the distributor. This warranty is on a return to factory for repair basis.
- CET does not accept liability for any damage caused by meter malfunctions. CET accepts no responsibility for the suitability of the meter to the application for which it was purchased.
- Failure to install, set up or operate the meter according to the instructions herein will void the warranty.
- Only CET's duly authorized representative may open your meter. The unit should only be opened in a fully anti-static environment. Failure to do so may damage the electronic components and will void the warranty.

Glossary

ADR	= Adaptive Data Rate
AppEUI	= Application Identifier
AppKey	= AES-128 key
CT	= Current Transformer
DevEUI	= End-Device Identifier (Global Unique Node ID in IEEE EUI64 address)
DI/DO	= Digital Input/Output
DMD	= Demand
DR	= Data Recorder
FIFO	= First-In-First-Out
I4	= Neutral Current
In	= Neutral Current (Calculated)
IoT	= Internet of Things
IR or Ir	= Residual Current
LoRaWAN	= Long Range Network Protocol
MB	= Mega Byte
OTAA	= Over the Air Activation
PAR	= Peak to Average Ratio
PF	= Power Factor
PQ	= Power Quality
PT	= Potential Transformer
RMS	= Root Mean Square
RO	= Relay Output
RTD	= Resistance Temperature Detector
SCCT	= Split-Core Current Transformer
SOE	= Sequence of Event
TDD	= Total Demand Distortion
TEHD	= Total Even Harmonics Distortion
THD	= Total Harmonic Distortion
TOHD	= Total Odd Harmonics Distortion
TOU	= Time of Use
TransCnt	= Transmission Counter
Ull	= Line-to-Line Voltage
Uln	= Line-to-Neutral Voltage
WAGES	= Water, Air, Gas, Electricity, Stream

Table of Contents

Chapter 1 Introduction	1
1.1 Overview	1
1.2 Features	1
1.3 PMC-350-C's application in a wireless IoT based EMS using LoRaWAN network	3
1.4 Getting more information	3
Chapter 2 Installation.....	4
2.1 Appearance.....	4
2.1.1 Main Unit	4
2.1.2 Split-Core CTs' Appearances & Specifications	5
2.1.3 PMC-BCC-350-2 Connecting Cable (For 800A/40mA and 1600A/40mA SCCT only)	5
2.1.4 PMC-PMA-4 Panel Mounting Adapter	5
2.2 Unit Dimensions.....	6
2.3 Terminal Dimensions	6
2.4 CT Dimensions	7
2.4.1 5A/2mA, 100A/40mA, 200A/40mA or 400A/40mA SCCT	7
2.4.2 800A Split-Core CT (PMC-SCCT-800A-40mA-A).....	7
2.4.3 1600A Split-Core CT (PMC-SCCT-1600A-40mA-A).....	8
2.5 Panel Mounting Adapter Dimensions	8
2.6 Mounting	8
2.6.1 DIN-Rail Mounting	8
2.6.2 Panel Mounting.....	9
2.7 Wiring Mode	9
2.8 SCCT Installation	10
2.8.1 Wiring for 5A/2mA, 100A/40mA, 200A/40mA or 400A/40mA SCCT	10
2.8.2 Wiring for 800A/40mA or 1600A/40mA SCCT	10
2.9 RS-485 Wiring	11
2.10 Digital Input Wiring.....	11
2.11 Digital Output Wiring.....	11
2.12 Pulse Output Wiring	11
2.13 Residual Current (Ir) Wiring	12
2.14 RTD Input Wiring.....	12
2.15 Power Supply Wiring.....	12
Chapter 3 Front Panel	13
3.1 LED Indicator.....	13
3.2 LCD Testing.....	13
3.3 LCD Display Symbols	13
3.4 Data Display	14
3.5 Setup Configuration	16
3.5.1 Operations of Buttons.....	16
3.5.2 Setup Menu.....	16
3.5.3 Configuration	19
Chapter 4 Applications.....	21
4.1 Inputs and Outputs (Optional).....	21
4.1.1 Digital Inputs	21
4.1.2 Digital Outputs	21
4.1.3 Energy Pulse Output	21
4.1.4 RTD Input	21
4.1.5 IR Input.....	22
4.2 Power and Energy	22
4.2.1 Basic Measurements	22
4.2.2 Energy Measurements	22
4.2.3 Demand Measurements	22
4.3 Power Quality	23
4.3.1 Phase Angles	23
4.3.2 Unbalance	23

4.3.3 Harmonics	23
4.4 Setpoints	25
4.5 Logging.....	27
4.5.1 Max./Min. Log.....	27
4.5.2 Monthly Energy Log	27
4.5.3 Peak Demand Log	27
4.5.4 Daily and Monthly Freeze Log.....	28
4.5.5 SOE Log	28
4.5.6 Data Recorder Log.....	28
4.6 Time of Use (TOU).....	29
Chapter 5 Modbus Register Map	30
5.1 Basic Measurements.....	30
5.2 Energy Measurements	32
5.2.1 3-Phase Energy Measurements	32
5.2.2 Phase A (L1) Energy Measurements	33
5.2.3 Phase B (L2) Energy Measurements.....	33
5.2.4 Phase C (L3) Energy Measurements.....	34
5.3 DI Pulse Counter	35
5.4 Harmonic Measurements	35
5.4.1 Power Quality Measurements	35
5.4.2 Current Harmonic Measurements	36
5.4.3 Voltage Harmonic Measurements	36
5.5 Demands.....	36
5.5.1 Present Demands.....	36
5.5.2 Predicted Demands.....	37
5.5.3 Peak Demand Log of This Month (Since Last Reset)	37
5.5.4 Peak Demand Log of Last Month (Before Last Reset)	37
5.6 Max./Min. Log.....	38
5.6.1 Max. Log of This Month (Since Last Reset)	38
5.6.2 Min. Log of This Month (Since Last Reset)	39
5.6.3 Max. Log of Last Month (Before Last Reset)	40
5.6.4 Min. Log of Last Month (Before Last Reset)	41
5.6.5 Max./Min. Log Structure.....	41
5.7 Monthly Energy Log.....	42
5.8 Daily and Monthly Freeze Logs	43
5.8.1 Daily Freeze Log	43
5.8.2 Monthly Freeze Log.....	43
5.9 SOE Log	44
5.10 Data Recorder Log.....	47
5.11 Device Setup	47
5.11.1 Basic Setup	47
5.11.2 I/O Setup.....	49
5.11.3 Setpoint Setup	49
5.11.4 Comm. Setup	50
5.11.5 LoRaWAN Setup.....	50
5.11.6 Data Recorder Setup	51
5.12 TOU Setup.....	52
5.12.1 Basic	52
5.12.2 Season.....	53
5.12.3 Daily Profile	54
5.12.4 Alternate Days.....	55
5.13 Time	55
5.14 Remote Control.....	56
5.15 Clear/Reset Control.....	56
5.16 Meter Information	57
Chapter 6 LoRaWAN Application Protocol.....	59
6.1 Introduction	59

6.2 LoRaWAN Data Packet Definition	59
6.3 LoRaWAN Auto-Push Configuration.....	59
6.3.1 Packet Structure.....	59
6.4 Application Server.....	64
6.4.1 Application Server Request Format	64
6.4.2 Node Response Format.....	64
Appendix A Data Recorder Parameter List.....	65
Appendix B Data Recorder Default Settings.....	66
Appendix C Technical Specifications	67
Appendix D Standards of Compliance	69
Appendix E Ordering Guide	70
Contact us	72

Chapter 1 Introduction

This manual explains how to use the PMC-350-C Series Digital Three-Phase LoRaWAN DIN Energy Meter. Throughout the manual the term “meter” generally refers to all models.

This chapter provides an overview of the PMC-350-C meter and summarizes many of its key features.

1.1 Overview

The PMC-350-C is CET’s latest offer for the wireless IoT energy metering market using the LoRaWAN technology for its Long-Range wireless communication capability. Housed in a standard DIN form factor measuring 72x95x70mm, it is perfectly suited for extremely space restricting environment. With a standard RS-485 port and Modbus RTU protocol support, IEC 62053-21 Class 1 compliance as well as an optional AS923/KR920 or EU868 LoRaWAN Module, it becomes a vital component of an intelligent, distributed and IoT based EMS. The PMC-350-C optionally provides 4xDI for Status Monitoring, 2xRO for Control and Alarming or 2xSolid State Pulse Outputs for Energy Pulsing as well as 4xRTD and 1xIR Inputs for Temperature and Leakage Current measurements, respectively.

You can setup the meter via our free PMC Setup software. The meter is also supported by our PecStar® iEMS Integrated Energy Management System.

Following is a list of typical applications for the PMC-350-C:

- Industrial, Commercial and Utility Substation Metering
- Building, Factory and Process Automation
- Sub-metering and Cost Allocation
- Energy Management and Power Quality Monitoring
- LoRaWAN Class A/C IoT Energy Metering at AS923/KR920 or EU868 ISM Bands

1.2 Features

Ease of use

- Easy installation with DIN rail mounting, no tools required
- Support LoRaWAN Class C Node with the lowest latency for Server to End-Node communication
- Simple commissioning and low-cost deployment with Split-Core CT and wireless IoT protocol

Basic Measurements

- VLN, VLL per phase and Average
- Current per phase and Average with Calculated Neutral
- kW, kvar, kVA per phase and Total
- PF per phase and Total
- kWh, kvarh Import/Export/Net/Total and kVAh Total
- Frequency
- Device Operating Time (Running Hours)
- Optional Temperature and Residual Current measurements

Advanced Measurements

- U and I THD, TOHD, TEHD and Individual Harmonics up to 31st
- Current TDD, TDD Odd, TDD Even, K-Factor and Crest Factor
- U and I Unbalance and Phase Angles
- Fundamental kW and PF
- 12 Monthly Energy Logs of kWh/kvarh Import/Export/Total/Net, kVAh, kvarh Q1-Q4
- Demands, Predicted Demands and Peak Demands for kW/kvar/kVA Total and per phase Current with Timestamp for This Month and Last Month (or Since Last Reset and Before Last Reset)
- Two TOU schedules, each providing
 - 12 Seasons
 - 20 Daily Profiles, each with 12 Periods in 15-minute interval
 - 90 Holidays or Alternate Days
 - 8 Tariffs, each providing the following information
 - kWh/kvarh Import/Export, kVAh
 - kW/kvar/kVA Max. Demands

Setpoints

- 10 user programmable Setpoints with extensive list of monitoring parameters including Voltage, Current, Power and THD, Temperature, etc.
- Configurable thresholds, time delays and DO triggers

SOE Log

- 100 events time-stamped to ± 1 ms resolution
- Setup changes, Setpoint, DI status changes, DO operations, Clear Actions, Ir and Temperature Alarm, etc.

Max./Min. Logs

- Max./Min. Log with Timestamp for real-time measurements such as Voltage, Current, In, Freq., kW, kvar, kVA, PF, Unbalance, K-factor, Crest Factor and THD.
- Configurable for This Month/Last Month or Before/Since Last Reset

Data Recorder Log

- 5 Data Recorders of 16 parameters, up to 10,000 logs each for real-time measurements, Harmonics, Energy, Demand, TOU, Pulse Counters, etc.
- Recording interval from 1 minute to 40 days
- Available through Modbus communications only

Freeze Logs

- Daily and Monthly Log with timestamps for kWh, kvarh, kVAh Total and Peak Demands for kW, kvar, kVA Total
- Available through Modbus and LoRaWAN communications for 60 Daily Freeze records (2 months) and 36 Monthly Freeze records (3 years)

Optional Inputs and Outputs

- Digital Inputs
 - 4 channels, volts free dry contact, 24VDC internally wetted
 - 1000Hz sampling for status monitoring with programmable debounce
 - Pulse counting with programmable weight for each channel
- Digital Outputs
 - 2 Form A mechanical relays for alarming and general purpose control
- Pulse Outputs
 - 2 Form A Solid State Relays for kWh and kvarh pulsing
- Residual Current Input
 - Ir Input for Residual Current measurement (CT not included)
- RTD Temperature Inputs
 - Supporting PT100 sensor (not included) with a wide measurement range (-40 °C to 200 °C)

Communications

- Optically isolated RS485 port at 1200 to 38,400 bps
- Modbus RTU protocol
- Optional LoRaWAN support at AS923/KR920 or EU868 for IoT applications

Real-time Clock

- Battery-backed Real-time Clock with 6ppm accuracy (<0.5s per day)

Autonomous Data Push with the LoRaWAN Option

- DevEUI (End-Device Identifier), AppEUI (Application Identifier) and AppKey (AES-128 key) for OTAA activation
- User selectable Auto-Push Data Packages of real-time measurements, Energy & Demands, Harmonics, Max./Min. Logs, Freeze Logs, I/O and Setpoint status can be autonomously pushed to the LoRaWAN Network Server in configurable interval

*Not all measurements are available via the wireless LoRaWAN option

System Integration

- Supported by our PecStar® iEMS and PMC Setup via Modbus RTU protocol
- Easy integration into other Automation or SCADA systems via Modbus RTU protocol or IoT based Energy Management System via LoRaWAN

1.3 PMC-350-C's application in a wireless IoT based EMS using LoRaWAN network

The PMC-350-C series meter can be used to monitor 3P4W/3P3W/1P3W/1P2W power system and autonomously and wirelessly pushes its real-time data and other information to a LoRaWAN Application Server via a LoRaWAN Gateway for an IoT based Energy Management System.

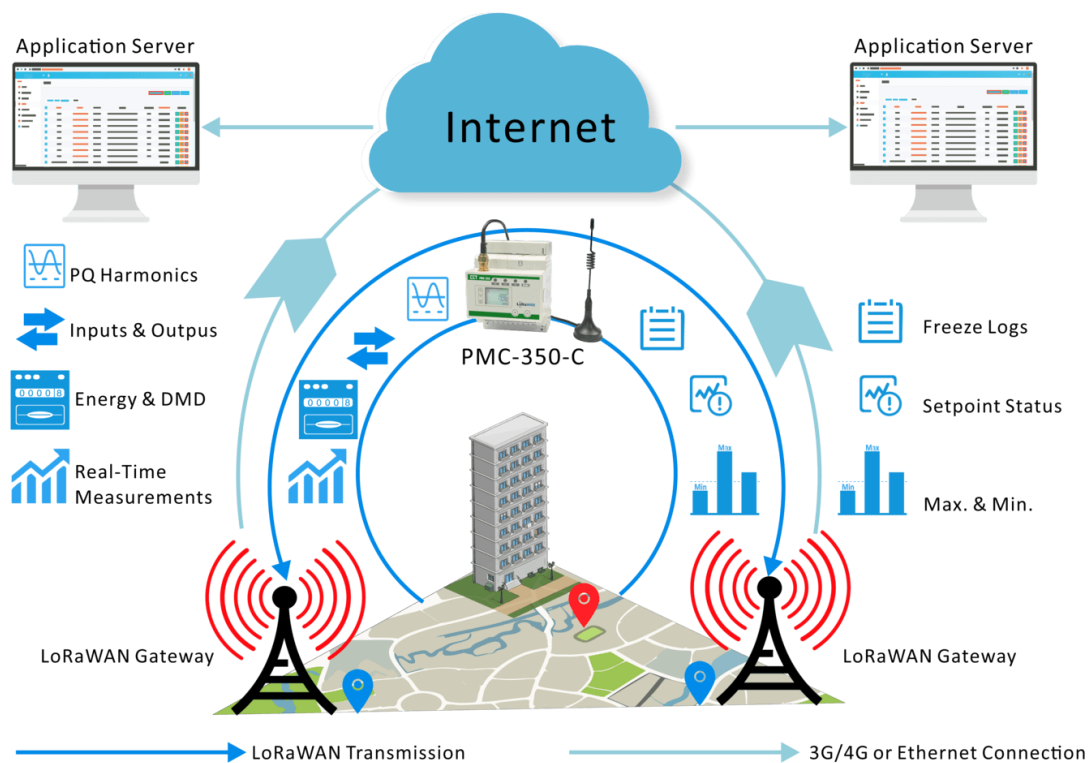

Figure 1- 1 PMC-350-C's application in a wireless IoT based EMS using LoRaWAN network

1.4 Getting more information

Additional information is available from CET via the following sources:

- Visit www.cet-global.com
- Contact your local representative
- Contact CET directly via support@cet-global.com

Chapter 2 Installation



Caution

Installation of the PMC-350-C should only be performed by qualified, competent personnel who have the appropriate training and experience with high voltage and current devices. The meter must be installed in accordance with all local and national electrical codes.

During the operation of the meter, hazardous voltages are present at the input terminals. Failure to observe precautions can result in serious or even fatal injury and equipment damage.

2.1 Appearance

2.1.1 Main Unit



Figure 2-1 Appearance

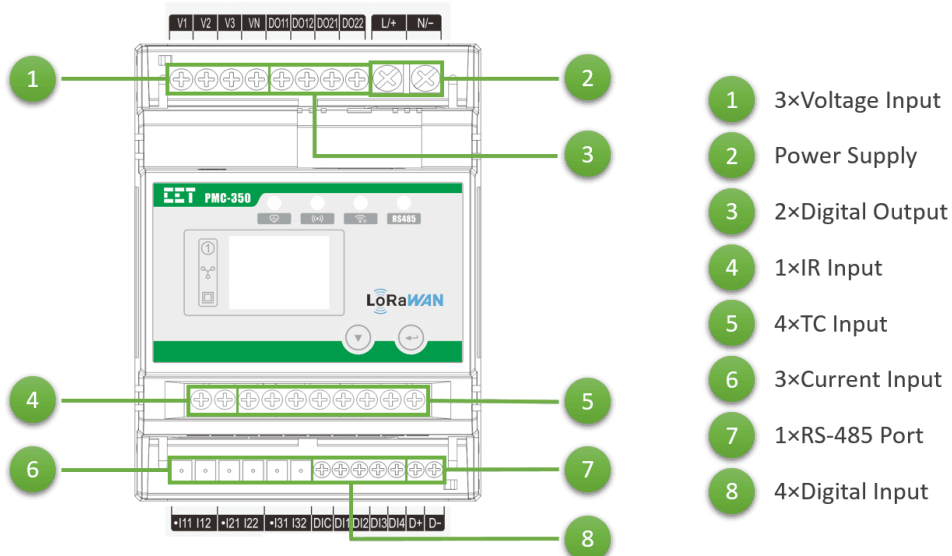

Figure 2-2 Terminals Diagram

2.1.2 Split-Core CTs' Appearances & Specifications

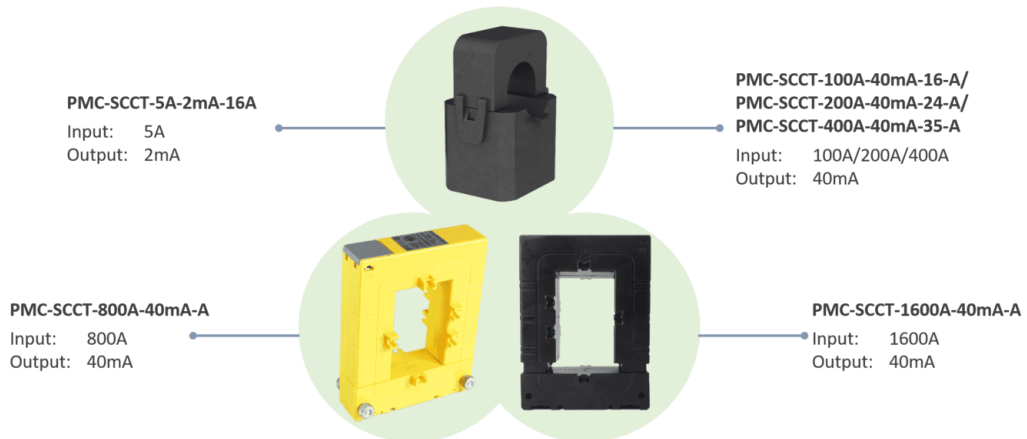

Figure 2-3 Split-Core CTs' Appearances & Specifications

2.1.3 PMC-BCC-350-2 Connecting Cable (For 800A/40mA and 1600A/40mA SCCT only)



Figure 2-4 PMC-BCC-350-2 Connecting Cable

2.1.4 PMC-PMA-4 Panel Mounting Adapter



Figure 2-5 PMC-PMA-4 Panel Mounting Adapter

2.2 Unit Dimensions

Unit: mm

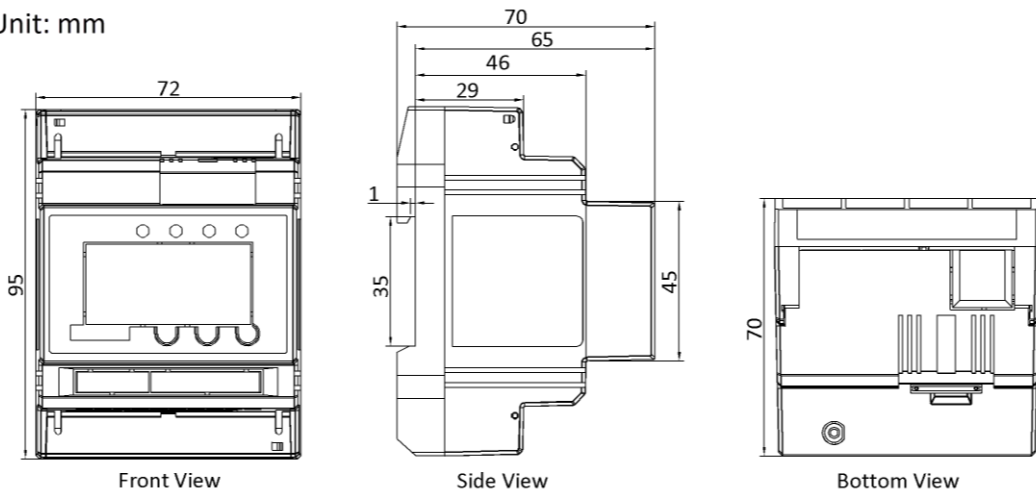
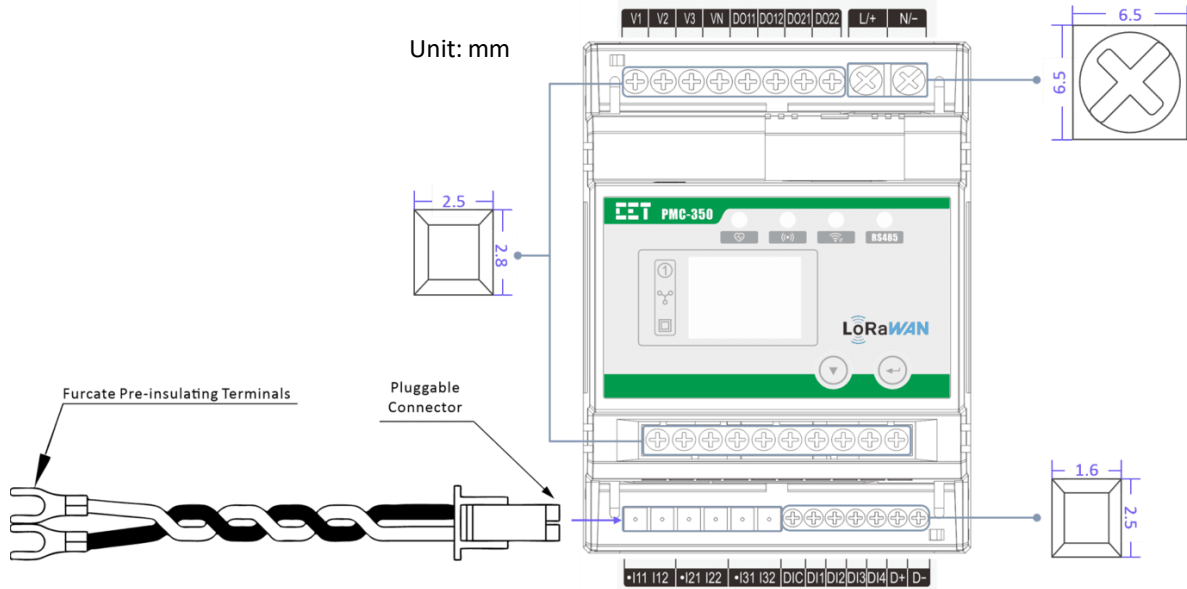

Figure 2-6 Unit Dimensions

2.3 Terminal Dimensions



No.	Terminal	Terminal Dimensions	Wire Size	Max. Torque
1	Voltage Input (V1, V2, V3, VN)	2.5mm x 2.8mm	1.5mm ²	4.5 kgf·cm/M2.5 (3.9 lbf·in)
	DO (DO11, DO12, DO21, DO22)			
	Ir (1, 2)			
	TC (3 to 10)			
2	Power Supply (L/+, N/-)	6.5mm x 6.5mm	1.5mm ² -0.5mm ² (16AWG - 20AWG)	6 kgf·cm/M3 (5.2 lbf·in)
3	DI (DI1 to DI4)	1.6mm x 2.5mm	0.75mm ²	2.5 kgf·cm/M2 (2.2 lbf·in)
	RS485 (D+, D-)			

Table 2-1 Terminal Dimensions

2.4 CT Dimensions

2.4.1 5A/2mA, 100A/40mA, 200A/40mA or 400A/40mA SCCT

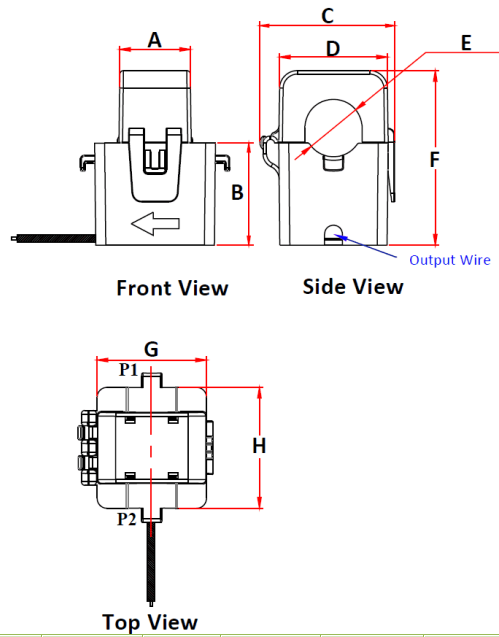

Model	A	B	C	D	E	F	G	H
PMC-SCCT-5A-2mA-16-A	19.9	28.6	38	30.26	∅16.1	48.9	30.7	33.9
PMC-SCCT-100A-40mA-16-A	19.9	28.6	38	30.26	∅16.1	48.9	30.7	33.9
PMC-SCCT-200A-40mA-24-A	20	40.5	53.5	44.3	∅24.1	70.0	45.0	40.2
PMC-SCCT-400A-40mA-35-A	22.5	47	67	57.3	∅35.1	83	58.2	42.8

Unit: mm

Figure 2-7 5A/2mA, 100A/40mA, 200A/40mA or 400A/40mA SCCTs Dimension

2.4.2 800A Split-Core CT (PMC-SCCT-800A-40mA-A)

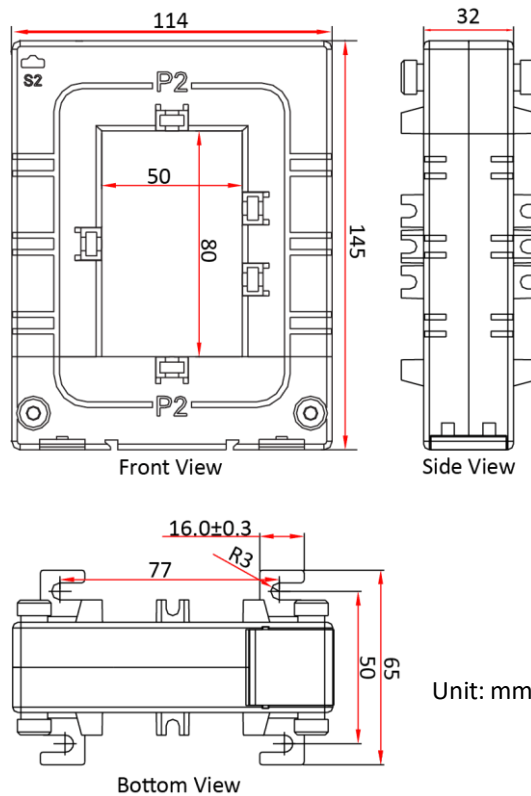

Unit: mm

Figure 2-8 800A SCCT Dimension

2.4.3 1600A Split-Core CT (PMC-SCCT-1600A-40mA-A)

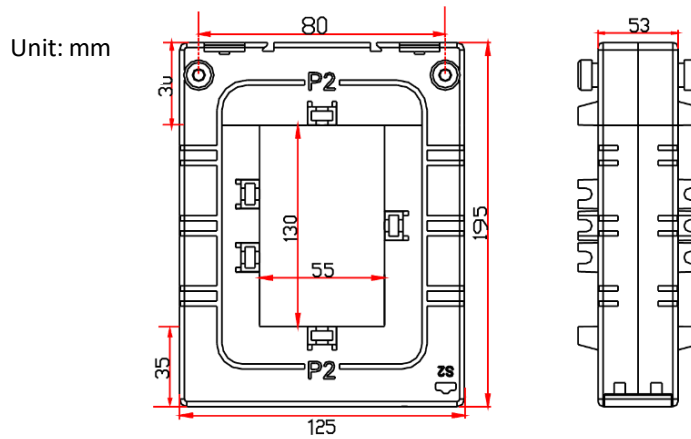

Figure 2-9 1600A SCCT Dimension

2.5 Panel Mounting Adapter Dimensions

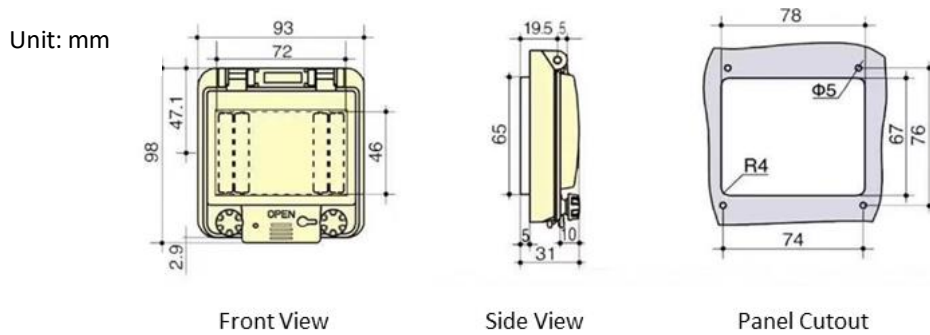

Figure 2-10 Panel Mounting Adapter Dimensions

2.6 Mounting

The PMC-350-C should be installed in a dry environment with no dust and kept away from heat, radiation and electrical noise source.

2.6.1 DIN-Rail Mounting

- Before installation, make sure that the DIN rail is already in place
- Move the installation clips at the back of the PMC-350-C downward to the “unlock” position
- Align the top of the mounting channel at the back of the PMC-350-C at an angle against the top of the DIN rail as shown in **Figure 2-11** below
- Rotate the bottom of the PMC-350-C towards the back while applying a slight pressure to make sure that the device is completely and securely fixed on to the DIN rail
- Push the installation clips upward to the “lock” position to secure the PMC-350-C on to the DIN Rail

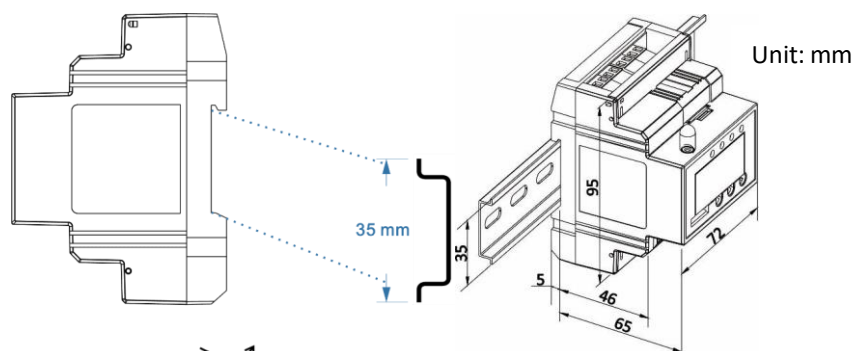

Figure 2-11 DIN-Rail Installation

2.6.2 Panel Mounting

- Remove the four plastic strips from the back of the Front Enclosure. Align the Front Enclosure in front of the 78x67mm panel cutout and line it up with the mounting holes.
- Install the two brackets from behind the panel to the Front Enclosure with the supplied screws. Install the device on the DIN Rail, fit the device through the 78x67mm panel cutout and then secure the DIN Rail onto the brackets with the supplied screws.
- Close the transparent cover and make sure the cover is securely latched. Install the two black thumb screws through the front holes at the bottom of the transparent cover.



Figure 2-12 Panel Mounting

2.7 Wiring Mode

Please read this section carefully before installation and choose the correct wiring method for your power system.

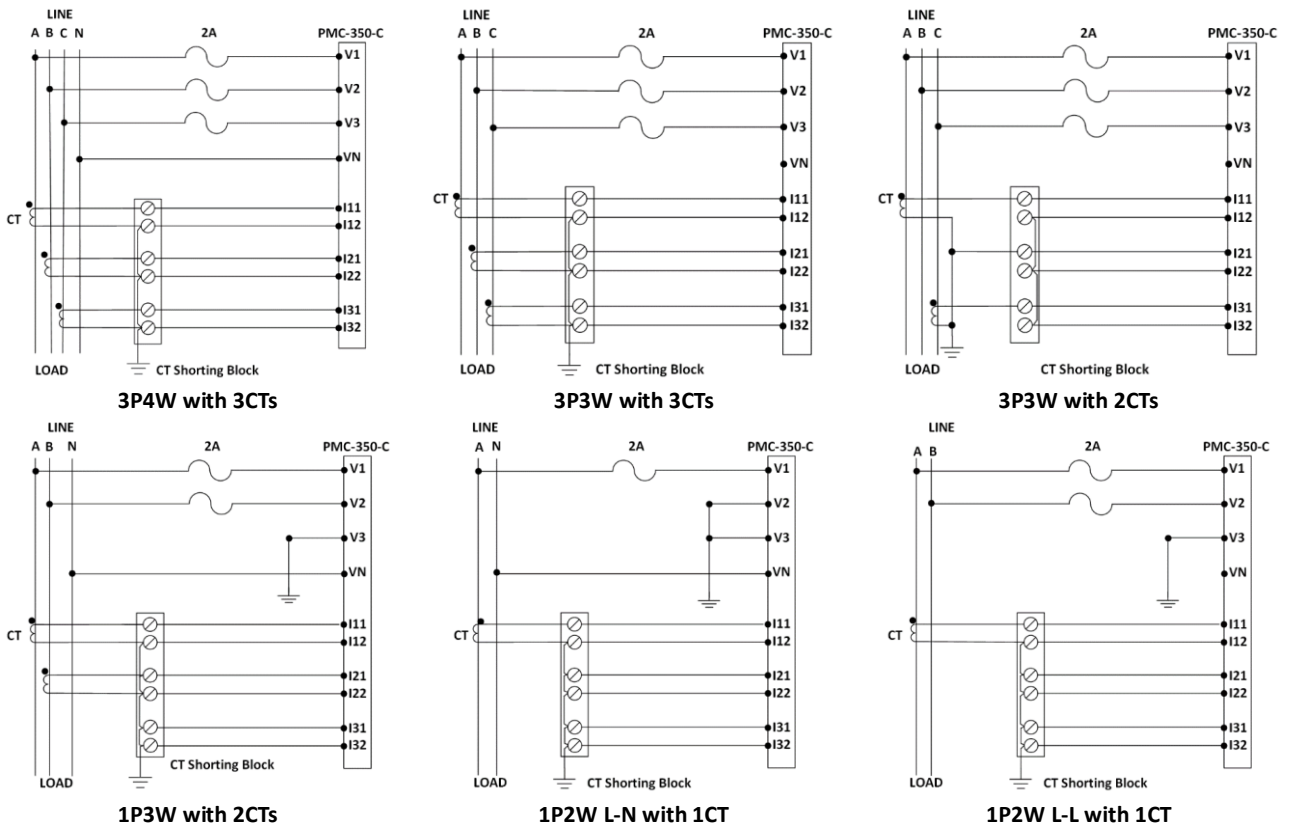

Figure 2-13 Wiring Mode

2.8 SCCT Installation



Please make sure that the circuit is de-energized before installing the SCCT for maximum safety. Do not open circuit the SCCT's secondary output under any circumstances while the circuit is energized. Failure to observe proper precaution while working with this product may result in serious injury or death.

2.8.1 Wiring for 5A/2mA, 100A/40mA, 200A/40mA or 400A/40mA SCCT

Steps:

- These SCCTs come with a pluggable connector at the end of the output wires. Insert the 2-pin pluggable connector securely into the Current Input terminal on the PMC-350-C.
- Open the SCCT by slightly pulling on the clip. Please ensure that SCCT's contact surface is clean and without contaminants for best accuracy performance.
- Put the cable through the opening of the SCCT and make sure that Current flow direction is aligned with the arrow marking on the SCCT. Close the SCCT and make sure that the clip is securely latched.
- Secure the cable to the SCCT with a wire strap.



Figure 2-14 5A/2mA, 100A/40mA, 200A/40mA or 400A/40mA SCCT Installation

2.8.2 Wiring for 800A/40mA or 1600A/40mA SCCT

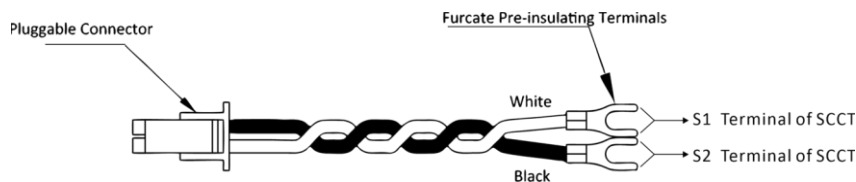

Steps:

- Connect the white and black leads with the spade connector of the PMC-BCC-350-2 to the SCCT's S1 and S2 terminals, respectively, and insert the 2-pin pluggable connector to the meter's Current Input terminal of the PMC-350-C.
- Open the SCCT by removing the thumb-screws that hold the SCCT together and make sure that SCCT's contact surface is clean and without contaminants for best accuracy performance.
- Install the SCCT around the busbar and then carefully secure it using the provided mounting fixtures such as mounting bolts and insulation caps as shown below.
- Reassemble the SCCT and tighten the thumb screws.

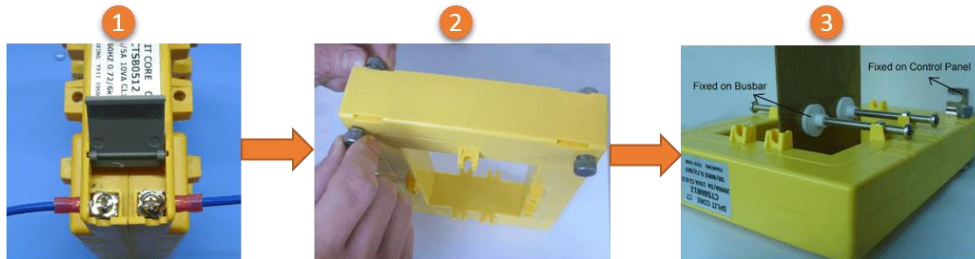

Figure 2-15 5A/2mA, 100A/40mA, 200A/40mA or 400A/40mA SCCT installation

Notes:

- Please separate the adjacent CTs by about 2 cm to reduce potential magnetic interference.
- Please ensure the Load Current does not exceed the CT's Primary Current specification.

2.9 RS-485 Wiring

The PMC-350-C provides one standard RS-485 port that supports the Modbus RTU protocol. Up to 32 devices can be connected on a RS-485 bus. The overall length of the RS-485 cable connecting all devices should not exceed 1200m.

If the master station does not have a RS-485 communications port, an Ethernet-to-RS-485 gateway or USB/RS-485 converter with optically isolated outputs and surge protection should be used. The following figure illustrates the RS-485 connections on the PMC-350-C.

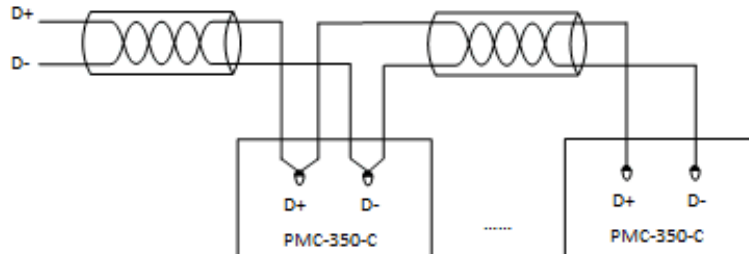

Figure 2-16 RS-485 Connections

2.10 Digital Input Wiring

The following figure illustrates the Digital Input connections:

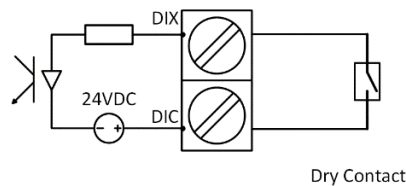

Figure 2-17 DI Connections

2.11 Digital Output Wiring

The following figure illustrates the Digital Output connections:

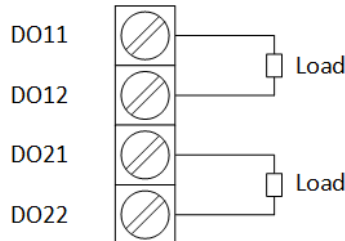

Figure 2-18 DO Connections

2.12 Pulse Output Wiring

The following figure illustrates the Pulse Output connections on the PMC-350-C when the **DO Mode** setup register is programmed for Energy Pulsing:

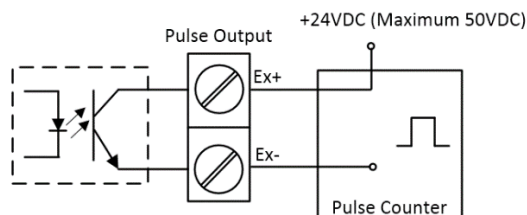

Figure 2-19 Pulse Output (Solid State Relay) Connections for Energy Pulsing

The following figure illustrates the Pulse Output (Solid State Relay) connections on the PMC-350-C when the **DO Mode** setup register is programmed for Digital Output:

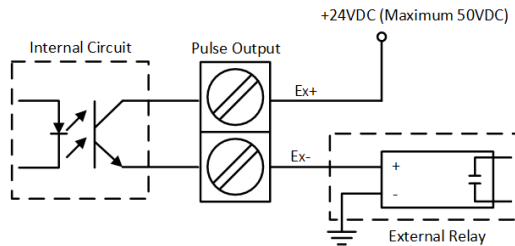

Figure 2-20 Pulse Output (Solid State Relay) Connections for Energy Pulsing

2.13 Residual Current (Ir) Wiring

The following figure illustrates the Residual Current connections on the PMC-350-C:

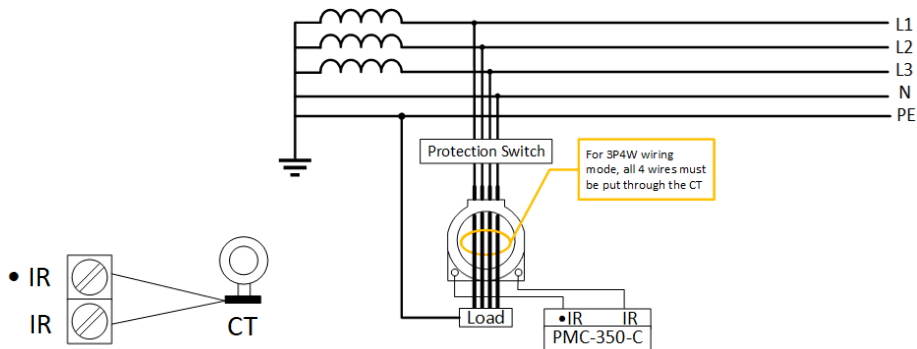

Figure 2-21 Residual Current Connections

2.14 RTD Input Wiring

The following figure illustrates the RTD Input connections on the PMC-350-C.

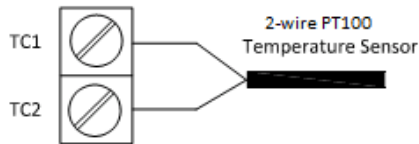

Figure 2-22 RTD Input Connections

2.15 Power Supply Wiring

For AC supply, connect the live wire to the L/+ terminal and the neutral wire to the N/- terminal.

For DC supply, connect the positive wire to the L/+ terminal and the negative wire to the N/- terminal.

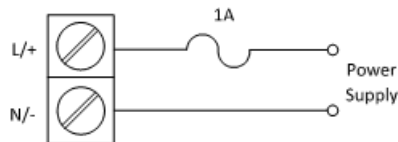

Figure 2-23 Power Supply Connections

Chapter 3 Front Panel

The meter’s LCD display screen and two buttons allow quick access to view measurements and meter information, configure the parameters and perform maintenance.

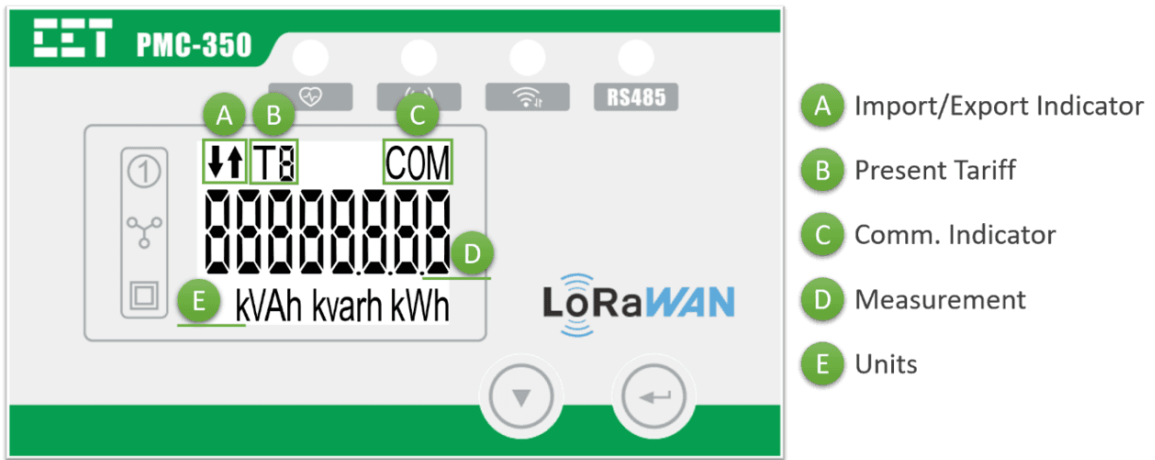

Figure 3-1 Front Panel Display

3.1 LED Indicator

There are four LED indicators on the PMC-350-C’s Front Panel as described below:

Indicator	Color	Status	Description
	Green	Blink once per second	Device is running normally
		Off	Device is running abnormally
	Green	Off	No LoRaWan Connection
		Blink for one second	LoRaWan Connection In Process
	Red	On	Connected to LoRaWan Gateway
		Flashing	Wireless Comm. Activities
	Red	Off	Wireless Comm. Inactive
		Flashing	RS485 Comm. Activities
	Red	Off	RS485 Comm. Inactive
		Flashing	RS485 Comm. Activities

Table 3-1 LED Indicators

3.2 LCD Testing

The PMC-350-C comes standard with an easy to read LCD display. The LCD screen will run a self-test after powering on. During the test, all LCD segments are illuminated before returning to the normal Data Display mode.

3.3 LCD Display Symbols

The following figure shows the LCD Display symbols based on “8”.

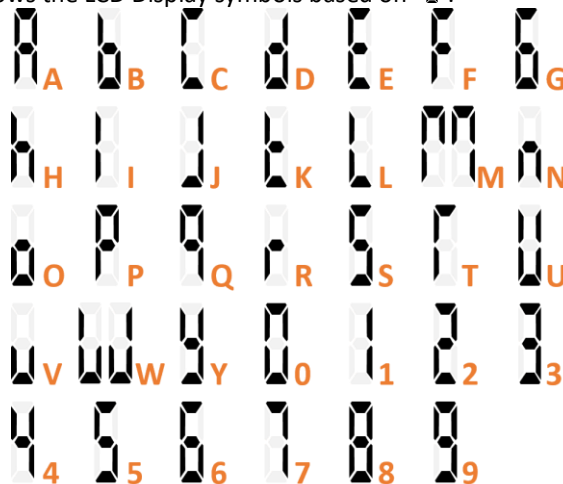

Figure 3-2 LCD Display Symbols

3.4 Data Display

The PMC-350-C has a **Default Display** that shows the kWh Imp parameter as shown below. The user can use the <▼> button to scroll and display other parameters. If there is no Front Panel activity for 20 seconds or longer, the LCD will return to the **Default Display**.



Figure 3-3 Default Display

The following table illustrates the available measurements in the **Data Display** mode. Depending on the **Wiring Mode** selected, certain measurements may not be available. For example, the per-phase UIn, UIn Average, In, per-phase kW, kvar, kVA and PF measurements are not available when the **Wiring Mode** is set to 3P3W, 1P2W L-L.

In **Data Display** mode, pressing <▼> button scrolls to the next parameter. Pressing <↔> at any time while in **Data Display** mode has no effect on the display.

Energy				
kWh Import	kWh Export	kvarh Import	kvarh Export	kVAh
Voltage				
Uab	Ubc	Uca	UII Average	Uan
Ubn	Ucn	UIn Average		
Current				
Ia	Ib	Ic	I Average	
Power				
kWa	kWb	kWc	kW Total	kvara
kVAh	kvarh	kWh	kVAh	kvarh



3.5 Setup Configuration

3.5.1 Operations of Buttons





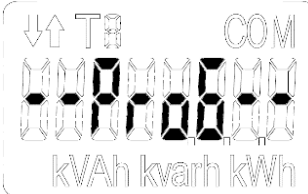
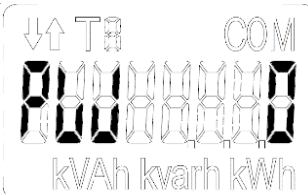

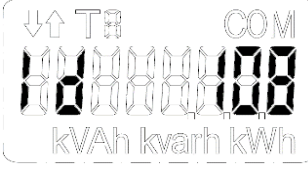
Making setup changes:

- Press <↵> for two seconds to enter **Setup Configuration**, and the LCD displays --PROG--.
- Press <▼> to advance to the Password page.
- A correct password must be entered before changes are allowed. The factory default password is 0000 (zero). Press the <↵> to select the parameter for modification. Use <▼> and <↵> to enter the correct password.
- Use <▼> to scroll to the desired sub-menu or setup parameter.
- Press <↵> to enter a sub-menu or select a setup parameter for modification.
- Once a parameter has been selected, its value will blink.
- Use <↵> and <▼> to make modification to the selected parameter.
- Press <↵> for two seconds to return to the main menu.
- Press <↵> for two seconds again to exit the **Setup Configuration** mode. The **Setup Configuration** will be automatically exited if there is no activity for 3 minutes or longer.

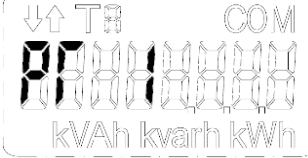
3.5.2 Setup Menu

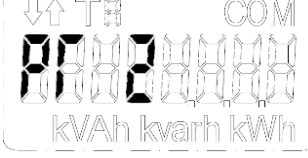
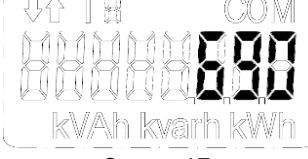
Displays	Button Description
 <p>Screen 1</p>	<p>Press <↵> for 2 seconds to enter Setup Configuration</p>
 <p>Screen 2</p>	<p>Press <▼> to advance to the Password page</p>
 <p>Screen 3</p>	<p>Enter the password first in order to make configuration changes. Default password is: 0000. Press the <↵> to move the cursor one digit to the left. Press <▼> increments the selected digit. If the cursor has reached the left most digit, pressing <↵> button again to confirm the password.</p>
 <p>Screen 4</p>	<p>Press <▼> to advance to Set Password. Press <↵> to change the device password.</p>
 <p>Screen 5</p>	<p>Press <▼> to advance to Unit ID. Press <↵> to change the device unit id</p>

 <p>Screen 6</p>	<p>Press <▼> to advance to Baud Rate. Press <←> to change the device baud rate.</p>
 <p>Screen 7</p>	<p>Press <▼> to advance to Comm. Port Config. Press <←> to change the Comm. Port configuration.</p>
 <p>Screen 8</p>	<p>Press <▼> to advance to LoRaWAN ADR (Adaptive Data Rate)³. Press <←> to change LoRaWAN_ADR Mode.</p>
 <p>Screen 9</p>	<p>Press <▼> to advance to LoRaWAN Power³. Press <←> to change LoRaWAN Power.</p>
 <p>Screen 10</p>	<p>Press <▼> to advance to LoRaWAN Datarate³. Press <←> to change LoRaWAN Data Rate.</p>
 <p>Screen 11</p>	<p>Press <▼> to advance to LoRaWAN Class³. Press <←> to change LoRaWAN Device Class.</p>
 <p>Screen 12</p>	<p>Press <▼> to advance to LoRaWAN TransCnt³. Press <←> to change LoRaWAN TransCnt.</p>

 <p>Screen 13</p>	<p>Press <▼> to advance to Meter's Wiring Mode. Press <←> to change the Meter's wiring mode settings.</p>
 <p>Screen 14</p>	<p>Press <▼> to advance to PT Primary.</p>
 <p>Screen 15</p>	<p>Press <▼> to view PT Primary. Press <←> to change the PT Primary setting.</p>
 <p>Screen 16</p>	<p>Press <▼> to advance to PT Secondary</p>
 <p>Screen 17</p>	<p>Press <▼> to view PT Secondary Press <←> to change the PT Secondary setting.</p>
 <p>Screen 18</p>	<p>Press <▼> to advance to CT Primary.</p>
 <p>Screen 19</p>	<p>Press <▼> to view CT Primary Press <←> to change the CT Primary setting</p>
 <p>Screen 20</p>	<p>Press <▼> to advance to CT Secondary.</p>
 <p>Screen 21</p>	<p>Press <▼> to view CT Secondary. Press <←> to change the CT Secondary setting</p>



 <p>Screen 22</p>	<p>Press <▼> to advance to view PF Convention. Press <←> to change PF Convention setting.</p>
 <p>Screen 23</p>	<p>Press <▼> to advance to kVA Algorithm. Press <←> to change the kVA Algorithm setting.</p>
 <p>Screen 24</p>	<p>Press <▼> to advance to Date. Press <←> to change the Date setting.</p>
 <p>Screen 25</p>	<p>Press <▼> to advance to Time. Press <←> to change the Time setting.</p>

Table 3-3 Setup Menu

Notes:

1. The access to the Setup Menu will terminate after 20s of inactivity and return to the **Default Display** screen.
2. The meter’s setup parameters can be browsed without entering the correct password, but changes are only allowed with the correct password.
3. Please refer to **Section 5.11.5** for more details about these parameters.

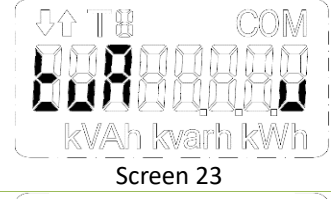
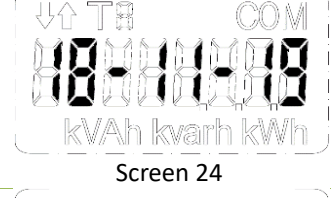
3.5.3 Configuration

The Setup Configuration mode provides access to the following setup parameters:

Label	Description	Range	Default
Main Menu			
Sub			
ProG	Setup Configuration	/	/
PW	Enter Password	0 to 9999	0
SET PW	Set New Password		
	Enter New Password	0 to 9999	0
	Comm. Parameters		
Id	Set Meter Unit ID	1 to 247	100
bd	Set Baud Rate in Bits Per Second (bps)	1200/2400/4800/ 9600/19200/38400	9600
CFG	Set Comm. Port Config.	8N2/8O1/8E1/ 8N1/8O2/8E2	8E1
ADR	Enable/Disable LoRaWAN_ADR function	On/off	On
P	Set the LoRaWAN transmission power	20/17/16/14/12/ 10/7/5/2 (dbm)	20
dr	Set the LoRaWAN data transmission rate	SF12/11/10/9/8/7	SF7
CLASS	Set the LoRaWAN device class	Class A/C	Class C
SCnt	Set the LoRaWAN Transmission Counter	1~8	8
	System Settings		
Wiring Mode	Set Meter’s wiring connection	DEMO/1P3W/3P3W/ 3P4W/1P2W L-N/ 1P2W L-L	3P4W
PT1	Set PT Primary	1-1000000	100
PT2	Set PT Secondary	1-690	100

CT1	Set CT Primary	1-30,000	100
CT2	Set CT Secondary	1-100	100
PF	Set PF Convention ¹⁾	IEC/IEEE/-IEEE	IEC
kVA	Set kVA Calculation Method ²⁾	V=Vector, S=Scalar	V
Date and Time			
Date	Enter the Current Date	YY-MM-DD	/
Time	Enter the Current Time	HH:MM:SS	/

Table 3-4 Setup Parameters

Notes:

1) Power Factor Convention (-IEEE is the same as IEEE but with the opposite sign):

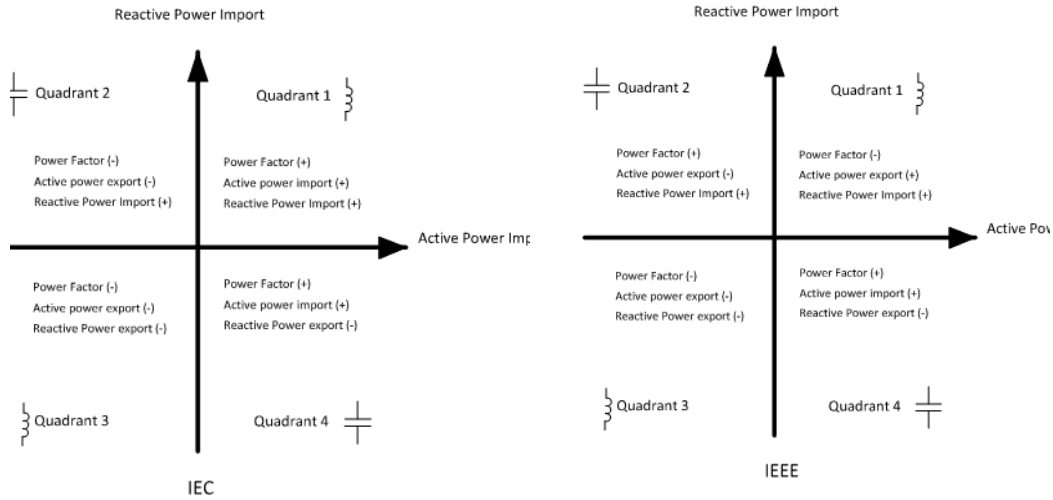

Figure 3-4 PF Convention

2) There are two ways to calculate kVA:

Mode V (Vector method): $kVA_{total} = \sqrt{kW_{total}^2 + kvar_{total}^2}$

Mode S (Scalar method): $kVA_{total} = kVA_a + kVA_b + kVA_c$

Chapter 4 Applications

4.1 Inputs and Outputs (Optional)

4.1.1 Digital Inputs

The PMC-350-C comes standard with four self-excited Digital Inputs that are internally wetted at 24VDC. Digital Inputs on the PMC-350-C can be used in the following applications:

- 1) **Digital Input** The digital inputs are typically used for status monitoring which can help prevent equipment damage, improve maintenance, and track security breaches. The real-time statuses of the Digital Inputs are available on the Front Panel LCD Display as well as through communications. Changes in Digital Input status are stored as events in the SOE Log in 1 ms resolution.
- 2) **Pulse Counting** Pulse counting is supported with programmable pulse weight and facilitates WAGES (Water, Air, Gas, Electricity and Steam) information collection.

The following table describes the DI setup parameters that can be programmed over communications:

Setup Parameter	Definition	Options/Default*
Dlx Function	Each DI can be configured as a Status Input or Pulse Counter.	0=Status Input* 1=Pulse Counter
Dlx Debounce	Specifies the minimum duration the DI must remain in the Active or Inactive state before a DI state change is considered to be valid.	1 to 9999 (ms) 20*
Dlx Pulse Weight	Specifies the incremental value for each received pulse. This is only used when a DI is configured as a Pulse Counter.	1* to 1,000,000

Table 4-1 DI Setup Parameters

4.1.2 Digital Outputs

The PMC-350-C comes optionally with two Form A Electrometrical Relays or Solid State Relays, which both can be used for setpoint alarming, load control, or remote control applications.

Digital Outputs on the PMC-350-C can be used in the following applications:

- 1) **Remote Control** Remotely operated over communications via our free PMC Setup software or PecStar® iEMS Integrated Energy Management System.
- 2) **Control Setpoint** Control Setpoints can be programmed to trigger DO action upon becoming active. Please refer to **Section 4.4** for a detailed description.

Since there are multiple ways to trigger the Digital Outputs on the PMC-350-C, a prioritized scheme has been developed to avoid conflicts between different applications. In general, Remote Control has the highest priority and can override Control Setpoint schemes. This scheme is equivalent to having an implicit Logical OR operation for the control of a Digital Output and may be useful in providing a generic alarm output signal.

4.1.3 Energy Pulse Output

The PMC-350-C comes optionally with two Solid State Relays used for energy pulsing. Energy Pulse Output is typically used for accuracy testing. The pulse constant can be configured through the **Pulse Constant** setup parameter as 10/100/1000/3200 pulses per kxh, where kxh may be kWh or kvarh.

4.1.4 RTD Input

The PMC-350-C optionally provides four RTD Inputs for temperature measurements. The PT100 sensors are not included. The 2-wire outputs of the PT100 sensor are connected to the RTD Input of the PMC-350-C if so equipped. The PMC-350-C can provide accurate temperature monitoring with the optional RTD inputs for measuring the temperature of the Neutral Conductor, Transformer or other equipment. There is an RTD Compensation register for each channel which can be used to compensate the measurement accuracy, and the compensation can be set according to formula:

$$\text{RTD Compensation} = 0.29 \times L \quad \text{where } L \leq 8 \text{ is the PT100 sensor's cable length in m}$$

4.1.5 IR Input

The PMC-350-C comes optionally with one IR input for Residual Current measurement via an external Residual Current transformer. The IR measurement can be set as the Setpoint Source to trigger an alarm when a threshold value is exceeded. The 3-Phase and Neutral conductors should be wired through the Residual Current CT without the PE (Protective Earth) wire as illustrated below.

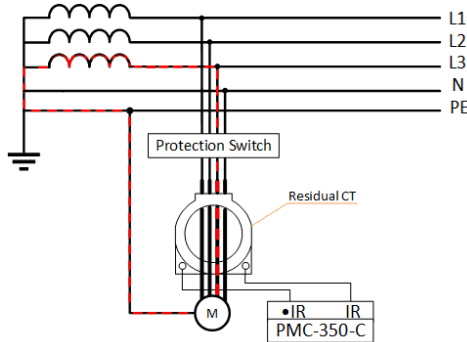

Figure 4-1 Example for Residual Current Measurement

4.2 Power and Energy

4.2.1 Basic Measurements

The PMC-350-C provides the following basic measurements which can be retrieved via the Front Panel or communication:

Parameter	Phase A	Phase B	Phase C	Total	Average
Uln	●	●	●	-	●
Ull	●	●	●	-	●
Current	●	●	●	-	●
kW	●	●	●	●	-
kvar	●	●	●	●	-
kVA	●	●	●	●	-
Power Factor	●	●	●	●	-
Frequency	●	-	-	-	-

Table 4-2 Basic Measurements

4.2.2 Energy Measurements

The PMC-350-C provides Energy measurements for active energy (kWh), reactive energy (kvarh) and apparent energy (kVAh) with a resolution of 0.01 kxh and maximum value of 10,000,000.00. When the maximum value is reached, the energy registers will automatically roll over to zero. The energy can be reset manually through the communication.

The PMC-350-C provides the following energy measurements:

Per-Phase & 3-Phase	kWh Import/Export/Net/Total
	kWh Import/Export of TOU T1-8
	kvarh Import/Export/Net/Total
	kvarh Import/Export of TOU T1-8
	kvarh of Q1/Q2/Q3/Q4
kVAh	kVAh of TOU T1-8

Table 4-3 Energy Measurement

4.2.3 Demand Measurements

Demand is defined as the average power consumption over a fixed interval (usually 15 minutes) based on the Sliding Window method. The PMC-350-C provides Present Demand and Predicted Demand for Ia, Ib, Ic, kW Total, kvar Total and kVA Total, updated once a second, as well as Max. Demand for Ia, Ib, Ic, kW Total, kvar Total and kVA Total of TOU Tariff 1 to 8 in This Month (Since Last Reset) and Last Month (Before Last Reset). Only Import Demand is provided for kW Total, kvar total and kVA Total. Predicted Demand is typically used for pre-alarming and to help users reduce power consumption using a Setpoint to warn that the Demand limit may be exceeded.

The PMC-350-C provides the following Demand setup parameters:

Setup Parameter	Definition	Options
Demand Period (Register: 6029)	1 to 60 minutes. For example, if the # of Sliding Windows is set as 1 and the Demand Period is 15, the demand cycle will be 1×15=15min.	1 to 60 mins Default=15
# of Sliding Windows (Register: 6030)	Number of Sliding Windows.	1 to 15 Default=1
Self-Read Time (Register: 6031)	The Self-Read Time allows the user to specify the time and day of the month for the Peak Demand Self-Read operation. The Self-Read Time supports three options: <ul style="list-style-type: none"> • A zero value means that the Self-Read will take place at 00:00 of the first day of each month. • A non-zero value means that the Self-Read will take place at a specific time and day based on the formula: Self-Read Time = Day * 100 + Hour where 0 ≤ Hour ≤ 23 and 1 ≤ Day ≤ 28. For example, the value 1512 means that the Self-Read will take place at 12:00pm on the 15th day of each month. • A 0xFFFF value will disable the automatic Self-Read operation. A manual reset will cause the Max. Demand of This Month to be transferred to the Max. Demand of Last Month and then reset. The terms This Month and Last Month will become Since Last Reset and Before Last Reset. 	Default=0xFFFF
Predicted Response (Register: 6031)	The Predicated Response shows the speed of the predicted demand output. A value between 70 and 99 is recommended for a reasonably fast response. Specify a higher value for higher sensitivity.	70 to 99 Default=70

Table 4-4 Demand Setup

4.3 Power Quality

4.3.1 Phase Angles

Phase analysis is used to identify the angle relationship between 3-phase Voltages and Currents.

For WYE connected systems, the per-phase difference of the Current and Voltage angles should correspond to the per-phase PF. For example, if the PF is 0.5 Lag and the Voltage phase angles are 0.0°, 240.0° and 120.0°, the Current phase angles should have the values of -60.0°, 180.0° and 60.0°.

4.3.2 Unbalance

The PMC-350-C provides Voltage and Current Unbalance measurements. The calculation method of Voltage and Current Unbalances is based on the ratio of Positive and Negative Sequence Components.

$$\text{Voltage Unbalance} = \frac{V_2}{V_1} \times 100\%$$

$$\text{Current Unbalance} = \frac{I_2}{I_1} \times 100\%$$

where

V1, V2 are the Positive and Negative Sequence Components for Voltage, respectively.

and

I1, I2 are the Positive and Negative Sequence Components for Current, respectively.

4.3.3 Harmonics

The PMC-350-C provides Voltage and Current with THD, TOHD, TEHD and up to the 31st individual harmonics analysis. Additionally, TDD, K-Factor, and Crest Factor for Current are provided as well. All harmonic parameters are available via the Front Panel or through communications.

The following table illustrates the available Voltage and Current Harmonics measurements on the PMC-350-C.

	Phase A/AB	Phase B/BC	Phase C/CA
Harmonic-Voltage	THD	THD	THD
	TEHD	TEHD	TEHD
	TOHD	TOHD	TOHD
	2 nd Harmonics	2 nd Harmonics	2 nd Harmonics
	31 st Harmonics	31 st Harmonics	31 st Harmonics

Harmonic-Current	THD	THD	THD
	TEHD	TEHD	TEHD
	TOHD	TOHD	TOHD
	TDD	TDD	TDD
	TEDD	TEDD	TEDD
	TODD	TODD	TODD
	K-Factor	K-Factor	K-Factor
	Crest Factor	Crest Factor	Crest Factor
	2 nd Harmonics	2 nd Harmonics	2 nd Harmonics
		...	
	31 st Harmonics	31 st Harmonics	31 st Harmonics

Table 4-5 Harmonic Measurements

Notes:

- 1) When the wiring mode is 1P2W L-L or 1P2W L-N, the harmonic measurements for Phase B/BC and C/CA are reserved.
- 2) When the wiring mode is 1P3W, the harmonic measurements for Phase C/CA are reserved.

4.3.3.1 THD & Fundamental

There are two methods for calculating the **THD**, which are based on Fundamental (THDf) and RMS (THDr). **Fundamental** is defined as the lowest frequency of a periodic waveform.

THDf:

$$THDf = \frac{\sqrt{\sum_{n=2}^{\infty} I_n^2}}{I_1} \times 100\%$$

THDr:

$$THDr = \frac{\sqrt{\sum_{n=2}^{\infty} I_n^2}}{\sqrt{\sum_{n=1}^{\infty} I_n^2}} \times 100\%$$

where I_1 represents the RMS value of the fundamental component, and I_n represents the RMS value for the n^{th} harmonic.

4.3.3.2 TDD

Total Demand Distortion (TDD) is defined as the ratio of the RMS of the Harmonic Current to the RMS of the Rated or Maximum Fundamental Current Demand.

TDD of Current is calculated by the formula below:

$$TDD = \frac{\sqrt{\sum_{n=1}^{\infty} I_n^2}}{I_L} \times 100\%$$

where

- I_L = Maximum Fundamental Current Demand
- n = Harmonic Order (1, 2, 3, 4, etc.)
- I_n = RMS Load Current at the n^{th} Harmonic

4.3.3.3 K-Factor

K-Factor is defined as the weighted sum of the Harmonic Load Current according to their effects on transformer heating, as derived from ANSI/IEEE C57.110. A **K-Factor** of 1.0 indicates a linear load (no harmonics). The higher the **K-Factor**, the greater the harmonic heating effect.

$$K - \text{Factor} = \frac{\sum_{n=1}^{n=n_{\max}} (I_n \cdot n)^2}{\sum_{n=1}^{n=n_{\max}} I_n^2}$$

where

- I_n = n^{th} Harmonic Current in RMS
- n_{\max} = Highest Harmonic order

4.3.3.4 Crest Factor

Crest Factor is defined as the **Peak to Average Ratio (PAR)**, and its calculation is illustrated below:

$$C = \frac{|X|_{\text{peak}}}{X_{\text{rms}}}$$

where

$|X|_{\text{peak}}$ = Peak amplitude of the waveform

X_{rms} = RMS value

4.4 Setpoints

The PMC-350-C comes standard with 10 user-programmable Setpoints which provide extensive control by allowing a user to initiate an action in response to a specific condition. Typical setpoint applications include alarming, fault detection and power quality monitoring.

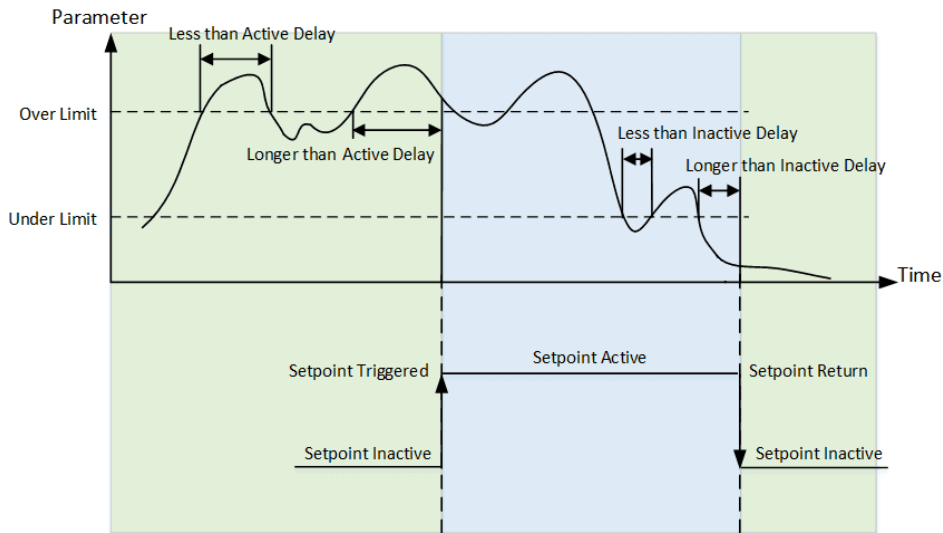

Figure 4-1 Over Setpoint

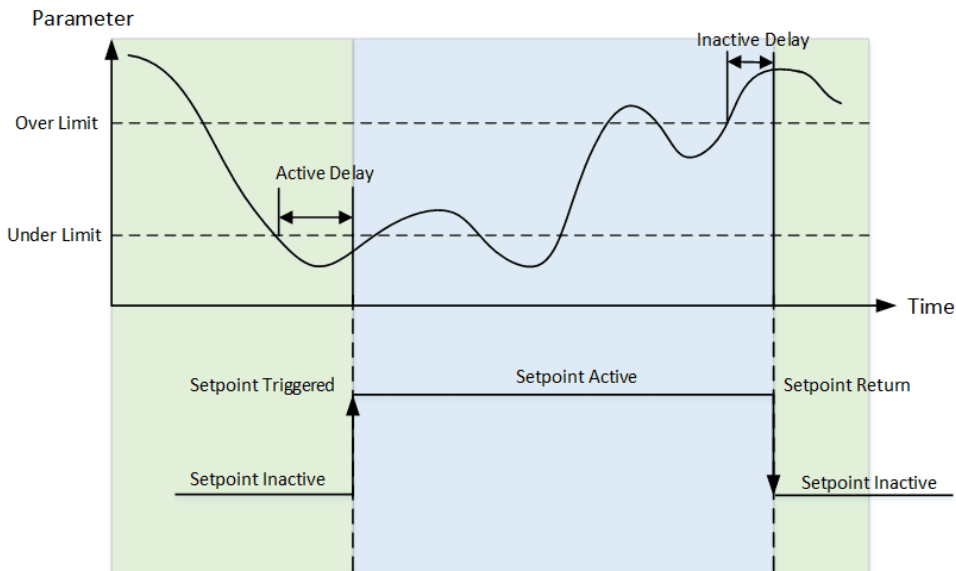

Figure 4-2 Under Setpoint

Setpoints can be programmed via the communications and have the following setup parameters:

Parameter	Definition	Options/Default*
Setpoint Type	Over or Under Setpoint.	0=Disabled* 1=Over Setpoint 2=Under Setpoint

Setpoint Parameter	Specify the parameter to be monitored.	See Table 4-7
Over Limit	Specify the value that the setpoint parameter must exceed for Over Setpoint to become active or for Under Setpoint to become inactive.	999,999
Under Limit	Specify the value that the setpoint parameter must go below for Over Setpoint to become inactive or for Under Setpoint to become active.	0*
Active Delay	Specify the minimum duration that the setpoint condition must be met before the setpoint becomes active. An event will be generated and stored in the SOE Log. The range of the Active Delay is between 0 and 9999 seconds.	0* to 9999s
Inactive Delay	Specify the minimum duration that the setpoint return condition must be met before the setpoint becomes inactive. An event will be generated and stored in the SOE Log. The range of the Inactive Delay is between 0 and 9999 seconds.	0* to 9999s
Trigger	Specify what action a setpoint would take when it becomes active.	0= None* 1=DO1 2=DO2

Table 4-6 Description for Setpoint Parameters

The table below illustrates the Setpoint Parameters.

Key	Setpoint Parameter	Scale	Resolution	Unit
0	None	-	-	-
1	UIn (Any Phase Voltage)	x1	0.01	V
2	UII (Any Line Voltage)			
3	I (Any Phase Current)		0.001	A
4	In (Calculated)			
5	Frequency		0.01	Hz
6	P (kW Total)			
7	Q (kvar Total)		0.001	W
8	S (kVA Total)			
9	PF (PF Total)			
10	P Pres. DMD (kW Total Present Demand)			
11	Q Pres. DMD (kvar Total Present Demand)			
12	S Pres. DMD (kVA Total Present Demand)			
13	P Pred. DMD (kW Total Predicted Demand)			
14	Q Pred. DMD (kvar Total Predicted Demand)		0.001%	100%
15	S Pred. DMD (kVA Total Predicted Demand)			
16	U THD			
17	U TOHD			
18	U TEHD			
19	I THD			
20	I TOHD			
21	I TEHD		100%	
22	U Unbal. (Voltage Unbalance)			
23	I Unbal. (Current Unbalance)		100%	
24	Reversal (Phase Reversal) ^{1, 2}			
25	IR (Residual Current)*	x1	1	mA
26-27	Reserved	-	-	-
28	TC1*	x1	0.1	°C
29	TC2*			
30	TC3*			
31	TC4*			
32	I1		0.001	A
33	I2			
34	I3			
35	Uan		0.01	V
36	Ubn			
37	Ucn			

* Appears only if the device is equipped with the appropriate option.

Table 4-7 Setpoint Parameters

Notes:

- When **Reversal** is set as the **Setpoint Parameter**, the **Setpoint Type** should be set to 1 (i.e., Over Setpoint). The **Setpoint Type=2** (i.e., Under Setpoint) is invalid. In addition, the **Over Limit** and **Under Limit** should be set as 0 and 1, respectively.

4.5 Logging

4.5.1 Max./Min. Log

The PMC-350-C records the **Max. Log** and **Min. Log of This Month (Since Last Reset)** and **Last Month (Before Last Reset)** with timestamp for 49 parameters. Each log includes the relevant parameter value and its timestamp. The recorded data is stored in non-volatile memory and will not suffer any loss in the event of a power failure. The PMC-350-C's Max./Min. Log records the following parameters:

Max./Min. Parameters					
Ia	Ib	Ic	I avg	Uan	Ubn
Ucn	Uln avg	Uab	Ubc	Uca	Ull avg
kWa	kWb	kWc	kW Total	kvara	kvarb
kvarc	kvar Total	kVAa	kVAb	kVAc	kVA Total
PFa	PFb	PFc	PF Total	Frequency	In(calculated)
Ia THD	Ib THD	Ic THD	Uan/Uab THD	Ubn/Ubc THD	Ucn/Uca THD
Ia K-Factor	Ib K-Factor	Ic K-Factor	Ia Crest-factor	Ib Crest-factor	Ic Crest-factor
U Unbal.	I Unbal.	IR*	TC1*	TC2*	TC3*
TC4*					

*Appears only if the device is equipped with the appropriate option.

Table 4-8 Max./Min. Measurements

The same **Self-Read Time** for the Max. Demand is used to specify the time and day of the month for the Max./Min. Self-Read operation. Please refer to **Section 4.2.3** for a complete description of the **Self-Read Time** and its operation.

The Max./Min. Log of This Month can be reset manually via communications.

4.5.2 Monthly Energy Log

The PMC-350-C stores monthly energy data for the present month and the last 12 months. The **Monthly Energy Log Self-read Time** setup parameter allows the user to specify the time and day of the month for the Recorder's Self-read operation via communications. The Monthly Energy Logs are stored in the meter's non-volatile memory and will not suffer any loss in the event of power failure, and they are stored on a first-in-first-out basis where the newest log will overwrite the oldest. The Monthly Energy Logs can be reset manually via communications.

The **Monthly Energy Log Self-Read Time** supports two options:

- A zero value means that the Self-Read will take place at 00:00 of the first day of each month.
- A non-zero value means that the Self-Read will take place at a specific time and day based on the formula: Energy Self-Read Time = Day x 100 + Hour where $0 \leq \text{Hour} \leq 23$ and $1 \leq \text{Day} \leq 28$. For example, the value 1512 means that the Self-Read will take place at 12:00pm on the 15th day of each month.

The PMC-350-C provides the following energy data for the present month and the last 12 months.

Active Energy	kWh Import	kWh Export	kWh Net	kWh Total
	T1 kWh Import	T8 kWh Import
	T1 kWh Export	T8 kWh Export
Reactive Energy	kvarh Import	kvarh Export	kvarh Net	kvarh Total
	T1 kvarh Import	T8 kvarh Import
	T1 kvarh Export	T8 kvarh Export
	kvarh Q1	kvarh Q2	kvarh Q3	kvarh Q4
Apparent Energy	kVAh			
	T1 kVAh	T8 kVAh

Table 4-9 Monthly Energy Log

4.5.3 Peak Demand Log

The PMC-350-C records the **Peak Demand of This Month (Since Last Reset)** and **Last Month (Before Last Reset)** with timestamp for Ia, Ib, Ic, kW Total, kvar Total and kVA Total as well as kW Total, kvar Total and kVA Total for TOU Tariffs 1 to 8.

The Peak Demand information can only be accessed through communications. Please refer to **Section 4.2.3** for a complete description of the **Self-Read Time** and its operation.

Peak Demand Logs of This Month (Since Last Reset) and Last Month (Before Last Reset)
3-Phase Current
kW/kvar/kVA Total
kW/kvar/kVA Total for TOU Tariffs 1 to 8

Table 4-10 Peak Demand

Notes:

- 1) When the wiring mode is 1P2W L-L or 1P2W L-N, the Demand measurements for Phase B and C are reserved.
- 2) When the wiring mode is 1P3W, the Demand measurements for Phase C are reserved.

4.5.4 Daily and Monthly Freeze Log

The PMC-350-C provides a **Daily Freeze Log** and a **Monthly Freeze Log** for Energy and Demand parameters and can store up to 60 daily freeze records (2 months) and 36 monthly freeze records (3 years). All Freeze Logs and their respective setup registers can only be accessed through communications. The PMC-350-C's Freeze Logs can freeze and record the following parameters:

Freeze Type	Parameters	Depth
Daily Freeze	kWh Total, kvarh Total, kVAh Total Peak Demands for kW Total, kvar Total and kVA Total	60
Monthly Freeze	kWh Total, kvarh Total, kVAh Total Peak Demands for kW Total, kvar Total and kVA Total with Timestamp	36

Table 4-11 Freeze Log

The **Daily Self-Read Time** setup parameter allows the user to specify the time of the day for the Daily Freeze Log Self-Read operation, while the **Monthly Self-Read Time** setup parameter allows the user to specify the time and day of the month for the Monthly Freeze Log Self-Read operation.

- 1) **Daily Freeze Self-Read Time** can be set to a zero value or a non-zero value:
 - A zero value means that the Self-Read will take place at 00:00 every day.
 - A non-zero value means that the Self-Read will take place at a specific time of the day based on the formula: Self-Read time = (Hour x 100 + Min) where $0 \leq \text{Hour} \leq 23$ and $0 \leq \text{Min} \leq 59$. For example, the value 1512 means that the Self-Read will take place at 15:12 of each day.
- 2) **Monthly Freeze Self-Read Time** can be set to a zero value or a non-zero value:
 - A zero value means that the Self-Read will take place at 00:00 of the first day of each month.
 - A non-zero value means that the Self-Read will take place at a specific time and day based on the formula: Monthly Self-Read Time = Day x 100 + Hour where $0 \leq \text{Hour} \leq 23$ and $1 \leq \text{Day} \leq 28$. For example, the value 1512 means that the Self-Read will take place at 12:00pm on the 15th day of each month.

4.5.5 SOE Log

The PMC-350-C's SOE Log can store up to 100 events such as Power-on, Power-off, Digital Input status changes, Digital Output status changes, Setup changes and Setpoint events in its non-volatile memory. Each event record includes the event classification, its relevant parameter values and a timestamp in ± 1 ms resolution. The SOE Log can be retrieved or reset via communications. If there are more than 100 events, the newest event will replace the oldest event on a First-In-First-Out basis.

4.5.6 Data Recorder Log

The PMC-350-C comes equipped with 4MB of memory and provides five Data Recorder capable of recording a maximum of 16 parameters. The Data Recorder Log is stored in the device's non-volatile memory and will not suffer any loss in the event of a power failure.

The programming of the Data Recorder is only supported over communication. The Data Recorder provides the following setup parameters:

Setup Parameters	Value/Option	Default
Trigger Mode	0=Disabled / 1=Triggered by Timer	1
Recording Mode	0=Stop-When-Full / 1=First-In-First-Out	1
Recording Depth	1 to 10,000 (entry)	5760
Recording Interval	60 to 3,456,000 seconds	900 s
Recording Offset	0 to 43,200 seconds, 0 indicates no offset.	0
No. of Parameters	0 to 16	See Appendix B Data Recorder Default Settings
Parameter 1 to 16	See Appendix A Data Recorder Parameter List	

Table 4-12 Setup Parameters for Data Recorder

The Data Recorder Log is only operational when the values of **Trigger Mode**, **Recording Mode**, **Recording Depth**, **Recording Interval**, and **No. of Parameters** are all non-zero.

The **Recording Offset** parameter can be used to delay the recording by a fixed time from the **Recording Interval**. For example, if the **Recording Interval** parameter is set to 3600 (hourly) and the **Recording Offset** parameter is set to 300 (5 minutes), the recording will take place at 5 minutes after the hour every hour, i.e. 00:05, 01:05, 02:05...etc. The value of the **Recording Offset** parameter should be less than the **Recording Interval** parameter.

4.6 Time of Use (TOU)

TOU is used for electricity pricing that varies depending on the time of day, day of week, and season. The TOU system allows the user to configure an electricity price schedule inside the PMC-350-C and accumulate energy consumption into different TOU tariffs based on the time of consumption. TOU programming is only supported through communications.

The TOU feature on PMC-350-C supports two TOU schedules, which can be switched at a pre-defined time. Each TOU schedule supports:

- Up to 12 seasons
- 90 Holidays or Alternate Days
- 20 Daily Profiles, each with 12 Periods in 15-minute interval
- 8 Tariffs

Each TOU schedule has the following setup parameters and can only be programmed via communications:

Setup Parameters	Definition	Options
Daily Profile #	Specify a daily rate schedule which can be divided into a maximum of 12 periods in 15-min intervals. Up to 20 Daily Profiles can be programmed for each TOU schedule.	1 to 20, the first period starts at 00:00 and the last period ends at 24:00.
Season #	A year can be divided into a maximum of 12 seasons. Each season is specified with a Start Date and ends with the next season's Start Date.	1 to 12, starting from January 1 st
Alternate Days #	A day can be defined as an Alternate Day, such as May 1 st . Each Alternate Day is assigned a Daily Profile.	1 to 90.
Day Types	Specify the day type of the week. Each day of a week can be assigned a day type such as Weekday1, Weekday2, Weekday3 and Alternate Days. The Alternate Day has the highest priority.	Weekday1, Weekday2, Weekday3 & Alternate Days.
Switching Time	Specify when to switch from one TOU schedule to another. Writing 0xFFFFFFFF to this parameter disables switching between TOU schedules.	Format: YYYYMMDDHH Default=0xFFFFFFFF

Table 4-13 TOU Setup Parameters

For each of the 8 Tariff Rates, the PMC-350-C provides the following information:

Energy: kWh Import/Export, kvarh Import/Export, kVAh for Per-Phase and Total

Peak Demand: kW/kvar/kVA of This Month (Since Last Reset) and Last Month (Before Last Reset).

The kWh Import/Export for TOU is available through the Front Panel or via communications.

Chapter 5 Modbus Register Map

This chapter provides a complete description of the Modbus register map (**Protocol Version 1.0**) for the PMC-350-C to facilitate the development of 3rd party communications driver for accessing information on the PMC-350-C. For a complete Modbus Protocol Specification, please visit <http://www.modbus.org>. The PMC-350-C supports the following Modbus functions:

- 1) Read Holding Registers (Function Code 0x03)
- 2) Force Single Coil (Function Code 0x05)
- 3) Preset Multiple Registers (Function Code 0x10)

The following table provides a description of the different data formats used for the Modbus registers. The PMC-350-C uses the Big Endian byte ordering system.

Format	Description
UINT16/INT16	Unsigned/Signed 16-bit Integer
UINT32/INT32	Unsigned/Signed 32-bit Integer
Float	IEEE 754 32-bit Single Precision Floating Point Number

5.1 Basic Measurements

Register	Property	Description	Format	Scale	Unit
0000	RO	Uan	Float	x1	V
0002	RO	Ubn	Float		
0004	RO	Ucn	Float		
0006	RO	Uln Average	Float		
0008	RO	Uab	Float		
0010	RO	Ubc	Float		
0012	RO	Uca	Float		
0014	RO	Ull Average	Float		
0016	RO	Ia	Float		A
0018	RO	Ib	Float		
0020	RO	Ic	Float		
0022	RO	I Average	Float		
0024	RO	kWa	Float		W
0026	RO	kWb	Float		
0028	RO	kWc	Float		
0030	RO	kW Total	Float		
0032	RO	kvara	Float		var
0034	RO	kvarb	Float		
0036	RO	kvarc	Float		
0038	RO	kvar Total	Float		
0040	RO	kVAa	Float		VA
0042	RO	kVAb	Float		
0044	RO	kVAc	Float		
0046	RO	kVA Total	Float		
0048	RO	PFa	Float		-
0050	RO	PFb	Float		
0052	RO	PFc	Float		
0054	RO	PF Total	Float		
0056	RO	Frequency	Float		Hz
0058	RO	Uan/Uab (3P3W) Angle	Float		°
0060	RO	Ubn/Ubc (3P3W) Angle	Float		°
0062	RO	Ucn/Uca (3P3W) Angle	Float		°
0064	RO	Ia Angle	Float	°	
0066	RO	Ib Angle	Float	°	
0068	RO	Ic Angle	Float	°	
0070	RO	In (Calculated)	Float	A	
0072	RO	I ^{r1}	Float	mA	
0074	RO	Displacement PFa	Float	-	
0076	RO	Displacement PFb	Float		
0078	RO	Displacement PFc	Float		
0080	RO	Displacement PF Total	Float		
0082~0085	RO	Reserved	Float	-	-

0086	RO	TC1 ¹	Float	x1	°C		
0088	RO	TC2 ¹	Float				
0090	RO	TC3 ¹	Float				
0092	RO	TC4 ¹	Float				
0094~0095	RO	Reserved	UINT16	-	-		
0096	RO	DI Status ^{1,2}	UINT16				
0097	RO	Reserved	UINT16				
0098	RO	DO Status ^{1,3}	UINT16				
0099	RO	Reserved	UINT16				
0100	RO	Setpoint Alarm Status ⁴	UINT16				
0101	RO	Wiring Diagnostic Status ⁵	UINT16				
0102	RO	SOE Pointer ⁶	UINT32				
0104	RO	Device Operating Time ⁷	UINT32			x0.1	Hour
0106	RO	Ir Self-diagnostic Status ⁸	UINT16			-	-
0107	RO	Temp. Self-diagnostic Status ⁹	UINT16				
0108	RO	Reserved	UINT16				
0109~0111	RO	Reserved	UINT16				
0112	RO	kWa H01	Float				
0114	RO	kWb H01	Float	x1	W		
0116	RO	kWc H01	Float				
0118	RO	kW Total H01	Float				
0120	RO	kW Total TH	Float				
0122	RO	DR1 Log Pointer ⁶	UINT32	-	-		
0124	RO	DR2 Log Pointer ⁶	UINT32				
0126	RO	DR3 Log Pointer ⁶	UINT32				
0128	RO	DR4 Log Pointer ⁶	UINT32				
0130	RO	DR5 Log Pointer ⁶	UINT32				

Table 5-1 Basic Measurements

Notes:

1. Ir, TC, DI Status and DO Status are only valid if the meter is equipped with corresponding options.
2. For the **DI Status** register, the bit values of B0 to B3 represent the states of DI1 to DI4, respectively, with “1” meaning Active (Closed) and “0” meaning Inactive (Open).
3. For the **DO Status** register, the bit values of B0 to B1 represent the states of DO1 and DO2, respectively, with “1” meaning DO Operated and “0” meaning DO Returned.
4. For the **Setpoint Status** register, the bit values indicate the various Setpoint states with “1” meaning Active and “0” meaning Inactive. The following table illustrates the details of the **Alarm Status** register.

Bit15	Bit14	Bit13	Bit12	Bit11	Bit10	Bit9	Bit8
Reserved	Reserved	Reserved	Reserved	Reserved	Reserved	Setpoint10	Setpoint9
Bit7	Bit6	Bit5	Bit4	Bit3	Bit2	Bit1	Bit0
Setpoint8	Setpoint7	Setpoint6	Setpoint5	Setpoint4	Setpoint3	Setpoint2	Setpoint1

Table 5-2 Setpoint Alarm Status Register

5. The following table illustrates the Wiring Diagnostic Status with 0 meaning Normal and 1 meaning Abnormal:

Bit	Event
B00	Summary Bit (Set if any other bit is set)
B01	Frequency is out of range between 45 to 65Hz (3P4W and 3P3W)
B02	Any phase voltage < 10% of PT Primary (Register 6000) (3P4W only)
B03	Any phase current < 1% of CT Primary (Register 6004) (3P4W or 3P3W)
B04~B05	Reserved
B06	Voltage Phase Reversal (3P4W or 3P3W)
B07	Current Phase Reversal (3P4W or 3P3W)
B08	Negative kW Total may be abnormal (3P4W or 3P3W)
B09	Negative kWa is may be abnormal (3P4W only)
B10	Negative kWb may be abnormal (3P4W only)
B11	Negative kWc may be abnormal (3P4W only)
B12	CTa polarity may be reversed (3P4W only)
B13	CTb polarity may be reversed (3P4W only)
B14	CTc polarity may be reversed (3P4W only)
B15	Reserved

Table 5-3 Wiring Diagnostic Status Register

6. The range of the Log Pointers (SOE and DRx) is between 0 and 0xFFFFFFFFH. The Log Pointer is incremented by one for every new log generated and will roll over to 0 if its current value is 0xFFFFFFFFH. If a Clear SOE Log or Clear DRx Log is performed via communications, the corresponding Log Pointer will be reset to zero. Therefore, any 3rd party software should assume that a Clear Log action has been performed if it sees the SOE Log Pointer rolling over to zero or to a value that is smaller than its own pointer.

7. The Device Operating Time means the accumulated Operating Time whenever any per-phase Current goes above 100mA. The Device Operating Time data is stored in non-volatile memory and will not suffer any loss in the event of a power failure.
8. For the Ir Self-diagnostic Status register, the bit values of B0 represents the states of external CT for Ir with “1” meaning faulty and “0” meaning normal.
9. For the Temp. Self-diagnostic Status register, the bit values of B0 to B3 represents the states of external Temperature Probe for TC1 to TC4, respectively, with “1” meaning faulty and “0” meaning normal.

5.2 Energy Measurements

The Energy registers have a maximum value of 1,000,000,000 and will roll over to zero automatically when it is reached. The actual energy value is 0.01 times of the register value.

5.2.1 3-Phase Energy Measurements

Register	Property	Description	Format	Scale	Unit
0500	RW	kWh Import	INT32	x0.01	kWh
0502	RW	kWh Export	INT32		
0504	RO	kWh Net	INT32		
0506	RO	kWh Total	INT32		
0508	RW	kvarh Import	INT32		kvarh
0510	RW	kvarh Export	INT32		
0512	RO	kvarh Net	INT32		
0514	RO	kvarh Total	INT32		
0516	RW	kVAh	INT32		kVAh
0518	RW	kvarh Q1	INT32		kvarh
0520	RW	kvarh Q2	INT32		
0522	RW	kvarh Q3	INT32		
0524	RW	kvarh Q4	INT32		
0526	RW	kWh Import of T1	INT32		kWh
0528	RW	kWh Export of T1	INT32		kvarh
0530	RW	kvarh Import of T1	INT32		
0532	RW	kvarh Export of T1	INT32		
0534	RW	kVAh of T1	INT32		
0536	RW	kWh Import of T2	INT32		kWh
0538	RW	kWh Export of T2	INT32		kvarh
0540	RW	kvarh Import of T2	INT32		
0542	RW	kvarh Export of T2	INT32		
0544	RW	kVAh of T2	INT32		
0546	RW	kWh Import of T3	INT32		kWh
0548	RW	kWh Export of T3	INT32		kvarh
0550	RW	kvarh Import of T3	INT32		
0552	RW	kvarh Export of T3	INT32		
0554	RW	kVAh of T3	INT32		
0556	RW	kWh Import of T4	INT32		kWh
0558	RW	kWh Export of T4	INT32		kvarh
0560	RW	kvarh Import of T4	INT32		
0562	RW	kvarh Export of T4	INT32		
0564	RW	kVAh of T4	INT32		
0566	RW	kWh Import of T5	INT32		kWh
0568	RW	kWh Export of T5	INT32		kvarh
0570	RW	kvarh Import of T5	INT32		
0572	RW	kvarh Export of T5	INT32		
0574	RW	kVAh of T5	INT32		
0576	RW	kWh Import of T6	INT32		kWh
0578	RW	kWh Export of T6	INT32		kvarh
0580	RW	kvarh Import of T6	INT32		
0582	RW	kvarh Export of T6	INT32		
0584	RW	kVAh of T6	INT32		
0586	RW	kWh Import of T7	INT32		kWh
0588	RW	kWh Export of T7	INT32		kvarh
0590	RW	kvarh Import of T7	INT32		
0592	RW	kvarh Export of T7	INT32		
0594	RW	kVAh of T7	INT32		
0596	RW	kWh Import of T8	INT32		kWh
0598	RW	kWh Export of T8	INT32		kvarh
0600	RW	kvarh Import of T8	INT32		
0602	RW	kvarh Export of T8	INT32		

0604	RW	kVAh of T8	INT32		kVAh
------	----	------------	-------	--	------

Table 5-4 3-phase Energy Measurements

5.2.2 Phase A (L1) Energy Measurements

Register	Property	Description	Format	Scale	Unit
0620	RW	kWh Import	INT32	x0.01	kWh
0622	RW	kWh Export	INT32		
0624	RO	kWh Net	INT32		
0626	RO	kWh Total	INT32		
0628	RW	kvarh Import	INT32		kvarh
0630	RW	kvarh Export	INT32		
0632	RO	kvarh Net	INT32		
0634	RO	kvarh Total	INT32		
0636	RW	kVAh	INT32		kVAh
0638	RW	kvarh Q1	INT32		kvarh
0640	RW	kvarh Q2	INT32		
0642	RW	kvarh Q3	INT32		
0644	RW	kvarh Q4	INT32		
0646	RW	kWh Import of T1	INT32		kWh
0648	RW	kWh Export of T1	INT32		kvarh
0650	RW	kvarh Import of T1	INT32		
0652	RW	kvarh Export of T1	INT32		
0654	RW	kVAh of T1	INT32		
0656	RW	kWh Import of T2	INT32		kWh
0658	RW	kWh Export of T2	INT32		kvarh
0660	RW	kvarh Import of T2	INT32		
0662	RW	kvarh Export of T2	INT32		
0664	RW	kVAh of T2	INT32		
0666	RW	kWh Import of T3	INT32		kWh
0668	RW	kWh Export of T3	INT32		kvarh
0670	RW	kvarh Import of T3	INT32		
0672	RW	kvarh Export of T3	INT32		
0674	RW	kVAh of T3	INT32		
0676	RW	kWh Import of T4	INT32		kWh
0678	RW	kWh Export of T4	INT32		kvarh
0680	RW	kvarh Import of T4	INT32		
0682	RW	kvarh Export of T4	INT32		
0684	RW	kVAh of T4	INT32		
0686	RW	kWh Import of T5	INT32	kWh	
0688	RW	kWh Export of T5	INT32	kvarh	
0690	RW	kvarh Import of T5	INT32		
0692	RW	kvarh Export of T5	INT32		
0694	RW	kVAh of T5	INT32		
0696	RW	kWh Import of T6	INT32	kWh	
0698	RW	kWh Export of T6	INT32	kvarh	
0700	RW	kvarh Import of T6	INT32		
0702	RW	kvarh Export of T6	INT32		
0704	RW	kVAh of T6	INT32		
0706	RW	kWh Import of T7	INT32	kWh	
0708	RW	kWh Export of T7	INT32	kvarh	
0710	RW	kvarh Import of T7	INT32		
0712	RW	kvarh Export of T7	INT32		
0714	RW	kVAh of T7	INT32		
0716	RW	kWh Import of T8	INT32	kWh	
0718	RW	kWh Export of T8	INT32	kvarh	
0720	RW	kvarh Import of T8	INT32		
0722	RW	kvarh Export of T8	INT32		
0724	RW	kVAh of T8	INT32		

Table 5-5 Phase A Energy Measurements

5.2.3 Phase B (L2) Energy Measurements

Register	Property	Description	Format	Scale	Unit
0740	RW	kWh Import	INT32	x0.01	kWh
0742	RW	kWh Export	INT32		

CET Electric Technology

0744	RO	kWh Net	INT32		
0746	RO	kWh Total	INT32		
0748	RW	kvarh Import	INT32		kvarh
0750	RW	kvarh Export	INT32		
0752	RO	kvarh Net	INT32		
0754	RO	kvarh Total	INT32		
0756	RW	kVAh	INT32		kVAh
0758	RW	kvarh Q1	INT32		kvarh
0760	RW	kvarh Q2	INT32		
0762	RW	kvarh Q3	INT32		
0764	RW	kvarh Q4	INT32		
0766	RW	kWh Import of T1	INT32		kWh
0768	RW	kWh Export of T1	INT32		
0770	RW	kvarh Import of T1	INT32		kvarh
0772	RW	kvarh Export of T1	INT32		
0774	RW	kVAh of T1	INT32		kVAh
0776	RW	kWh Import of T2	INT32		kWh
0778	RW	kWh Export of T2	INT32		
0780	RW	kvarh Import of T2	INT32		kvarh
0782	RW	kvarh Export of T2	INT32		
0784	RW	kVAh of T2	INT32		kVAh
0786	RW	kWh Import of T3	INT32		kWh
0788	RW	kWh Export of T3	INT32		
0790	RW	kvarh Import of T3	INT32		kvarh
0792	RW	kvarh Export of T3	INT32		
0794	RW	kVAh of T3	INT32		kVAh
0796	RW	kWh Import of T4	INT32		kWh
0798	RW	kWh Export of T4	INT32		
0800	RW	kvarh Import of T4	INT32		kvarh
0802	RW	kvarh Export of T4	INT32		
0804	RW	kVAh of T4	INT32		kVAh
0806	RW	kWh Import of T5	INT32		kWh
0808	RW	kWh Export of T5	INT32		
0810	RW	kvarh Import of T5	INT32		kvarh
0812	RW	kvarh Export of T5	INT32		
0814	RW	kVAh of T5	INT32		kVAh
0816	RW	kWh Import of T6	INT32		kWh
0818	RW	kWh Export of T6	INT32		
0820	RW	kvarh Import of T6	INT32		kvarh
0822	RW	kvarh Export of T6	INT32		
0824	RW	kVAh of T6	INT32		kVAh
0826	RW	kWh Import of T7	INT32		kWh
0828	RW	kWh Export of T7	INT32		
0830	RW	kvarh Import of T7	INT32		kvarh
0832	RW	kvarh Export of T7	INT32		
0834	RW	kVAh of T7	INT32		kVAh
0836	RW	kWh Import of T8	INT32		kWh
0838	RW	kWh Export of T8	INT32		
0840	RW	kvarh Import of T8	INT32		kvarh
0842	RW	kvarh Export of T8	INT32		
0844	RW	kVAh of T8	INT32		kVAh

Table 5-6 Phase B Energy Measurements

5.2.4 Phase C (L3) Energy Measurements

Register	Property	Description	Format	Scale	Unit	
0860	RW	kWh Import	INT32	x0.01	kWh	
0862	RW	kWh Export	INT32			
0864	RO	kWh Net	INT32			
0866	RO	kWh Total	INT32			
0868	RW	kvarh Import	INT32		kvarh	
0870	RW	kvarh Export	INT32			
0872	RO	kvarh Net	INT32			
0874	RO	kvarh Total	INT32			
0876	RW	kVAh	INT32			kVAh
0878	RW	kvarh Q1	INT32			kvarh

0880	RW	kvarh Q2	INT32		
0882	RW	kvarh Q3	INT32		
0884	RW	kvarh Q4	INT32		
0886	RW	kWh Import of T1	INT32		kWh
0888	RW	kWh Export of T1	INT32		
0890	RW	kvarh Import of T1	INT32		kvarh
0892	RW	kvarh Export of T1	INT32		
0894	RW	kVAh of T1	INT32		kVAh
0896	RW	kWh Import of T2	INT32		kWh
0898	RW	kWh Export of T2	INT32		
0900	RW	kvarh Import of T2	INT32		kvarh
0902	RW	kvarh Export of T2	INT32		
0904	RW	kVAh of T2	INT32		kVAh
0906	RW	kWh Import of T3	INT32		kWh
0908	RW	kWh Export of T3	INT32		
0910	RW	kvarh Import of T3	INT32		kvarh
0912	RW	kvarh Export of T3	INT32		
0914	RW	kVAh of T3	INT32		kVAh
0916	RW	kWh Import of T4	INT32		kWh
0918	RW	kWh Export of T4	INT32		
0920	RW	kvarh Import of T4	INT32		kvarh
0922	RW	kvarh Export of T4	INT32		
0924	RW	kVAh of T4	INT32		kVAh
0926	RW	kWh Import of T5	INT32		kWh
0928	RW	kWh Export of T5	INT32		
0930	RW	kvarh Import of T5	INT32		kvarh
0932	RW	kvarh Export of T5	INT32		
0934	RW	kVAh of T5	INT32		kVAh
0936	RW	kWh Import of T6	INT32		kWh
0938	RW	kWh Export of T6	INT32		
0940	RW	kvarh Import of T6	INT32		kvarh
0942	RW	kvarh Export of T6	INT32		
0944	RW	kVAh of T6	INT32		kVAh
0946	RW	kWh Import of T7	INT32		kWh
0948	RW	kWh Export of T7	INT32		
0950	RW	kvarh Import of T7	INT32		kvarh
0952	RW	kvarh Export of T7	INT32		
0954	RW	kVAh of T7	INT32		kVAh
0956	RW	kWh Import of T8	INT32		kWh
0958	RW	kWh Export of T8	INT32		
0960	RW	kvarh Import of T8	INT32		kvarh
0962	RW	kvarh Export of T8	INT32		
0964	RW	kVAh of T8	INT32		kVAh

Table 5-7 Phase C Energy Measurements

5.3 DI Pulse Counter

Register	Property	Description	Format	Range/Unit
1200	RW	DI1 Pulse Counter	UINT32	0 to 999,999,999 DI Pulse Counter= Pulse Counter x DI Pulse Weight
1202	RW	DI2 Pulse Counter	UINT32	
1204	RW	DI3 Pulse Counter	UINT32	
1206	RW	DI4 Pulse Counter	UINT32	

Table 5-8 DI Pulse Counter

5.4 Harmonic Measurements

5.4.1 Power Quality Measurements

Register	Property	Description	Format	Scale	Unit
1300	RO	Ia TDD	Float	x1	% (0.1 means 10%)
1302	RO	Ib TDD	Float		
1304	RO	Ic TDD	Float		
1306	RO	Ia TDD Odd	Float		
1308	RO	Ib TDD Odd	Float		
1310	RO	Ic TDD Odd	Float		
1312	RO	Ia TDD Even	Float		

1314	RO	Ib TDD Even	Float		
1316	RO	Ic TDD Even	Float		
1318	RO	Ia K-factor	Float		
1320	RO	Ib K-factor	Float		
1322	RO	Ic K-factor	Float		
1324	RO	Ia Crest-factor	Float		
1326	RO	Ib Crest-factor	Float		
1328	RO	Ic Crest-factor	Float		
1330	RO	Voltage Unbalance	Float		
1332	RO	Current Unbalance	Float		

Table 5-9 Power Quality Measurements

5.4.2 Current Harmonic Measurements

Register	Property	Description	Format	Scale	Unit
1400	RO	Ia THD	Float	x1	%
1402	RO	Ib THD	Float		
1404	RO	Ic THD	Float		
1406	RO	Ia TOHD	Float		
1408	RO	Ib TOHD	Float		
1410	RO	Ic TOHD	Float		
1412	RO	Ia TEHD	Float		
1414	RO	Ib TEHD	Float		
1416	RO	Ic TEHD	Float		
1418	RO	Ia HD02	Float		
1420	RO	Ib HD02	Float		
1422	RO	Ic HD02	Float		
1424~1590	RO	...	Float		
1592	RO	Ia HD31	Float		
1594	RO	Ib HD31	Float		
1596	RO	Ic HD31	Float		

Table 5-10 Current Harmonic Measurements

5.4.3 Voltage Harmonic Measurements

Register	Property	Description	Format	Scale	Unit
1600	RO	Uan/Uab THD	Float	x1	%
1602	RO	Ubn/Ubc THD	Float		
1604	RO	Ucn/Uca THD	Float		
1606	RO	Uan/Uab TOHD	Float		
1608	RO	Ubn/Ubc TOHD	Float		
1610	RO	Ucn/Uca TOHD	Float		
1612	RO	Uan/Uab TEHD	Float		
1614	RO	Ubn/Ubc TEHD	Float		
1616	RO	Ucn/Uca TEHD	Float		
1618	RO	Uan/Uab HD02	Float		
1620	RO	Ubn/Ubc HD02	Float		
1622	RO	Ucn/Uca HD02	Float		
1624~1790	RO	...	Float		
1792	RO	Uan/Uab HD31	Float		
1794	RO	Ubn/Ubc HD31	Float		
1796	RO	Ucn/Uca HD31	Float		

Table 5-11 Voltage Harmonic Measurements

Notes:

- 1) When the **Wiring Mode** is **3P3W** or **1P2W L-L**, the phase A/B/C voltage THD/TOHD/TEHD/HDxx is phase AB/BC/CA voltage THD/TOHD/TEHD/HDxx.
- 2) When the **Wiring Mode** is **1P2W L-N** or **1P2W L-L**, the L2 and L3 phase voltages THD/TOHD/TEHD/HDxx have no meaning, and their registers are reserved. When the **Wiring Mode** is **1P3W L-N**, the L3 phase voltages THD/TOHD/TEHD/HDxx have no meaning, and their registers are reserved.

5.5 Demands

5.5.1 Present Demands

Register	Property	Description	Format	Scale	Unit
3000	RO	Ia	Float	x1	A
3002	RO	Ib	Float		

3004	RO	Ic	Float		
3006	RO	kW Total	Float		W
3008	RO	kvar Total	Float		var
3010	RO	kVA Total	Float		VA

Table 5-12 Present Demand Measurements

5.5.2 Predicted Demands

Register	Property	Description	Format	Scale	Unit
3200	RO	Ia	Float	x1	A
3202	RO	Ib	Float		
3204	RO	Ic	Float		
3206	RO	kW Total	Float		
3208	RO	kvar Total	Float		
3210	RO	kVA Total	Float		

Table 5-13 Predicated Demands

5.5.3 Peak Demand Log of This Month (Since Last Reset)

Register	Property	Description	Format	Scale	Unit
3400~3405	RO	Ia	See Table 5-16	x1	A
3406~3411	RO	Ib			
3412~3417	RO	Ic			
3418~3423	RO	kW Total			
3424~3429	RO	kvar Total			
3430~3435	RO	kVA Total			
3436~3441	RO	kW Total of T1			
3442~3447	RO	kvar Total of T1			
3448~3453	RO	kVA Total of T1			
3454~3459	RO	kW Total of T2			
3460~3465	RO	kvar Total of T2			
3466~3471	RO	kVA Total of T2			
3472~3477	RO	kW Total of T3			
3478~3483	RO	kvar Total of T3			
3484~3489	RO	kVA Total of T3			
3490~3495	RO	kW Total of T4			
3496~3501	RO	kvar Total of T4			
3502~3507	RO	kVA Total of T4			
3508~3513	RO	kW Total of T5			
3514~3519	RO	kvar Total of T5			
3520~3525	RO	kVA Total of T5			
3526~3531	RO	kW Total of T6			
3532~3537	RO	kvar Total of T6			
3538~3543	RO	kVA Total of T6			
3544~3549	RO	kW Total of T7			
3550~3555	RO	kvar Total of T7			
3556~3561	RO	kVA Total of T7			
3562~3567	RO	kW Total of T8			
3568~3573	RO	kvar Total of T8			
3574~3579	RO	kVA Total of T8			

Table 5-14 Peak Demand Log of This Month

5.5.4 Peak Demand Log of Last Month (Before Last Reset)

Register	Property	Description	Format	Scale	Unit
3600~3605	RO	Ia	See Table 5-16	x1	A
3606~3611	RO	Ib			
3612~3617	RO	Ic			
3618~3623	RO	kW Total			
3624~3629	RO	kvar Total			
3630~3635	RO	kVA Total			
3636~3641	RO	kW Total of T1			
3642~3647	RO	kvar Total of T1			
3648~3653	RO	kVA Total of T1			
3654~3659	RO	kW Total of T2			
3660~3665	RO	kvar Total of T2			
3666~3671	RO	kVA Total of T2			

3672~3677	RO	kW Total of T3		W
3678~3683	RO	kvar Total of T3		var
3684~3689	RO	kVA Total of T3		VA
3690~3695	RO	kW Total of T4		W
3696~3701	RO	kvar Total of T4		var
3702~3707	RO	kVA Total of T4		VA
3708~3713	RO	kW Total of T5		W
3714~3719	RO	kvar Total of T5		var
3720~3725	RO	kVA Total of T5		VA
3726~3731	RO	kW Total of T6		W
3732~3737	RO	kvar Total of T6		var
3738~3743	RO	kVA Total of T6		VA
3744~3749	RO	kW Total of T7		W
3750~3755	RO	kvar Total of T7		var
3756~3761	RO	kVA Total of T7		VA
3762~3767	RO	kW Total of T8		W
3768~3773	RO	kvar Total of T8		var
3774~3779	RO	kVA Total of T8		VA

Table 5-15 Peak Demand Log of Last Month

Notes:

The following table illustrates Demand Data Structure:

Offset		Description
+0	High	Year - 2000
	Low	Month
+1	High	Day
	Low	Hour
+2	High	Minute
	Low	Second
+3	-	Millisecond
+4~+5	-	Record Value

Table 5-16 Demand Data Structure

5.6 Max./Min. Log

5.6.1 Max. Log of This Month (Since Last Reset)

Register	Property	Description	Format	Scale	Unit
4000~4005	RO	Uan	See Table 5-21	x1	V
4006~4011	RO	Ubn			
4012~4017	RO	Ucn			
4018~4023	RO	Uln Average			
4024~4029	RO	Uab			
4030~4035	RO	Ubc			
4036~4041	RO	Uca			
4042~4047	RO	Ull Average			
4048~4053	RO	Ia			A
4054~4059	RO	Ib			
4060~4065	RO	Ic			
4066~4071	RO	I Average			W
4072~4077	RO	kWa			
4078~4083	RO	kWb			
4084~4089	RO	kWc			
4090~4095	RO	kW Total			
4096~4101	RO	kvara			
4102~4107	RO	kvarb			
4108~4113	RO	kvarc			
4114~4119	RO	kvar Total			VA
4120~4125	RO	kVAa			
4126~4131	RO	kVAb			
4132~4137	RO	kVAc			
4138~4143	RO	kVA Total			
4144~4149	RO	PFa	-		
4150~4155	RO	PFb			
4156~4161	RO	PFc			

4162~4167	RO	PF Total			
4168~4173	RO	Frequency			Hz
4174~4179	RO	In (Calculated)			A
4180~4185	RO	Uan/Uab THD			% (0.1 means 10%)
4186~4191	RO	Ubn/Ubc THD			
4192~4197	RO	Ucn/Uca THD			
4198~4203	RO	Ia THD			
4204~4209	RO	Ib THD			-
4210~4215	RO	Ic THD			
4216~4221	RO	Ia K-factor			
4222~4227	RO	Ib K-factor			
4228~4233	RO	Ic K-factor			
4234~4239	RO	Ia Crest-factor			
4240~4245	RO	Ib Crest-factor			
4246~4251	RO	Ic Crest-factor			
4252~4257	RO	Voltage Unbalance			
4258~4263	RO	Current Unbalance			
4264~4269	RO	Ir			A
4270~4275	RO	TC1			°C
4276~4281	RO	TC2			
4282~4287	RO	TC3			
4288~4293	RO	TC4			

Table 5-17 Max. Log of This Month (Since Last Reset)

5.6.2 Min. Log of This Month (Since Last Reset)

Register	Property	Description	Format	Scale	Unit
4300~4305	RO	Uan	See Table 5-21	x1	V
4306~4311	RO	Ubn			
4312~4317	RO	Ucn			
4318~4323	RO	UIn Average			
4324~4329	RO	Uab			
4330~4335	RO	Ubc			
4336~4341	RO	Uca			
4342~4347	RO	Ull Average			
4348~4353	RO	Ia			
4354~4359	RO	Ib			
4360~4365	RO	Ic			
4366~4371	RO	I Average			
4372~4377	RO	kWa			
4378~4383	RO	kWb			
4384~4389	RO	kWc			
4390~4395	RO	kW Total			
4396~4401	RO	kvara			
4402~4407	RO	kvarb			
4408~4413	RO	kvarc			
4414~4419	RO	kvar Total			
4420~4425	RO	kVAa			
4426~4431	RO	kVAb			
4432~4437	RO	kVAc			
4438~4443	RO	kVA Total			
4444~4449	RO	PFa			
4450~4455	RO	PFb			
4456~4461	RO	PFc			
4462~4467	RO	PF Total			
4468~4473	RO	Frequency			
4474~4479	RO	In (Calculated)			
4480~4485	RO	Uan/Uab THD			
4486~4491	RO	Ubn/Ubc THD			
4492~4497	RO	Ucn/Uca THD			
4498~4503	RO	Ia THD			
4504~4509	RO	Ib THD			
4510~4515	RO	Ic THD			
4516~4521	RO	Ia K-factor			
4522~4527	RO	Ib K-factor			
4528~4533	RO	Ic K-factor			

4534~4539	RO	Ia Crest-factor			
4540~4545	RO	Ib Crest-factor			
4546~4551	RO	Ic Crest-factor			
4552~4557	RO	Voltage Unbalance			
4558~4563	RO	Current Unbalance			
4564~4569	RO	Ir			A
4570~4575	RO	TC1			
4576~4581	RO	TC2			
4582~4587	RO	TC3			°C
4588~4593	RO	TC4			

Table 5-18 Min. Log of This Month (Since Last Reset)

5.6.3 Max. Log of Last Month (Before Last Reset)

Register	Property	Description	Format	Scale	Unit	
4600~4605	RO	Uan	See Table 5-21	x1	V	
4606~4611	RO	Ubn				
4612~4617	RO	Ucn				
4618~4623	RO	UIn Average				
4624~4629	RO	Uab				
4630~4635	RO	Ubc				
4636~4641	RO	Uca				
4642~4647	RO	UII Average				
4648~4653	RO	Ia				A
4654~4659	RO	Ib				
4660~4665	RO	Ic				
4666~4671	RO	I Average				W
4672~4677	RO	kWa				
4678~4683	RO	kWb				
4684~4689	RO	kWc			var	
4690~4695	RO	kW Total				
4696~4701	RO	kvara				
4702~4707	RO	kvarb			VA	
4708~4713	RO	kvarc				
4714~4719	RO	kvar Total				
4720~4725	RO	kVAa			-	
4726~4731	RO	kVAb				
4732~4737	RO	kVAc				
4738~4743	RO	kVA Total				
4744~4749	RO	PFa				
4750~4755	RO	PFb				
4756~4761	RO	PFc				
4762~4767	RO	PF Total				
4768~4773	RO	Frequency				Hz
4774~4779	RO	In (Calculated)				A
4780~4785	RO	Uan/Uab THD				% (0.1 means 10%)
4786~4791	RO	Ubn/Ubc THD				
4792~4797	RO	Ucn/Uca THD				
4798~4803	RO	Ia THD			-	
4804~4809	RO	Ib THD				
4810~4815	RO	Ic THD				
4816~4821	RO	Ia K-factor				
4822~4827	RO	Ib K-factor				
4828~4833	RO	Ic K-factor				
4834~4839	RO	Ia Crest-factor				
4840~4845	RO	Ib Crest-factor				
4846~4851	RO	Ic Crest-factor				
4852~4857	RO	Voltage Unbalance				
4858~4863	RO	Current Unbalance				
4864~4869	RO	Ir	A			
4870~4875	RO	TC1	°C			
4876~4881	RO	TC2				
4882~4887	RO	TC3				
4888~4893	RO	TC4				

Table 5-19 Max. Log of Last Month (Before Last Reset)

5.6.4 Min. Log of Last Month (Before Last Reset)

Register	Property	Description	Format	Scale	Unit	
4900~4905	RO	Uan	See Table 5-21	x1	V	
4906~4911	RO	Ubn				
4912~4917	RO	Ucn				
4918~4923	RO	Uln Average				
4924~4929	RO	Uab				
4930~4935	RO	Ubc				
4936~4941	RO	Uca				
4942~4947	RO	Ull Average				
4948~4953	RO	Ia				A
4954~4959	RO	Ib				
4960~4965	RO	Ic				
4966~4971	RO	I Average			W	
4972~4977	RO	kWa				
4978~4983	RO	kWb				
4984~4989	RO	kWc				
4990~4995	RO	kW Total			var	
4996~5001	RO	kvara				
5002~5007	RO	kvarb				
5008~5013	RO	kvarc			VA	
5014~5019	RO	kvar Total				
5020~5025	RO	kVAa				
5026~5031	RO	kVAb				
5032~5037	RO	kVAc			-	
5038~5043	RO	kVA Total				
5044~5049	RO	PFa				
5050~5055	RO	PFb				
5056~5061	RO	PFc			Hz	
5062~5067	RO	PF Total				
5068~5073	RO	Frequency				
5074~5079	RO	In (Calculated)			A	
5080~5085	RO	Uan/Uab THD				
5086~5091	RO	Ubn/Ubc THD			% (0.1 means 10%)	
5092~5097	RO	Ucn/Uca THD				
5098~5103	RO	Ia THD				
5104~5109	RO	Ib THD				
5110~5115	RO	Ic THD				
5116~5121	RO	Ia K-factor				-
5122~5127	RO	Ib K-factor				
5128~5133	RO	Ic K-factor				
5134~5139	RO	Ia Crest-factor				
5140~5145	RO	Ib Crest-factor	A			
5146~5151	RO	Ic Crest-factor				
5152~5157	RO	Voltage Unbalance				
5158~5163	RO	Current Unbalance	°C			
5164~5169	RO	Ir				
5170~5175	RO	TC1				
5176~5181	RO	TC2				
5182~5187	RO	TC3				
5188~5193	RO	TC4				

Table 5-20 Min. Log of Last Month (Before Last Reset)

5.6.5 Max./Min. Log Structure

Offset		Description
+0	High	Year - 2000
	Low	Month
+1	High	Day
	Low	Hour
+2	High	Minute
	Low	Second
+3	-	Millisecond
+4~+5	-	Record Value

Table 5-21 Max./Min. Structure

5.7 Monthly Energy Log

Register	Property	Description	Format	Scale	Unit
0980	RW	Month ¹⁾	INT16	0* to 12	
0981	RO	High-order Byte: Year (0-99) Low-order Byte: Month (1-12)	INT16	Time Stamp (20YY/MM/DD HH:MM:SS)	
0982	RO	High-order Byte: Day (1-31) Low-order Byte: Hour (0-23)	INT16		
0983	RO	High-order Byte: Minute (0-59) Low-order Byte: Second (0-59)	INT16		
0984	RW	kWh Import	INT32		
0986	RW	kWh Export	INT32	x0.01	kWh
0988	RO	kWh Net	INT32		
0990	RO	kWh Total	INT32		
0992	RW	kvarh Import	INT32		
0994	RW	kvarh Export	INT32	x0.01	kvarh
0996	RO	kvarh Net	INT32		
0998	RO	kvarh Total	INT32		
1000	RW	kVAh	INT32		
1002	RW	kvarh Q1	INT32	x0.01	kvarh
1004	RW	kvarh Q2	INT32		
1006	RW	kvarh Q3	INT32		
1008	RW	kvarh Q4	INT32		
1010	RW	kWh Import of T1	INT32	x0.01	kWh
1012	RW	kWh Export of T1	INT32		
1014	RW	kvarh Import of T1	INT32		
1016	RW	kvarh Export of T1	INT32		
1018	RW	kVAh of T1	INT32	x0.01	kVAh
1020	RW	kWh Import of T2	INT32		
1022	RW	kWh Export of T2	INT32		
1024	RW	kvarh Import of T2	INT32		
1026	RW	kvarh Export of T2	INT32	x0.01	kvarh
1028	RW	kVAh of T2	INT32		
1030	RW	kWh Import of T3	INT32		
1032	RW	kWh Export of T3	INT32		
1034	RW	kvarh Import of T3	INT32	x0.01	kvarh
1036	RW	kvarh Export of T3	INT32		
1038	RW	kVAh of T3	INT32		
1040	RW	kWh Import of T4	INT32		
1042	RW	kWh Export of T4	INT32	x0.01	kWh
1044	RW	kvarh Import of T4	INT32		
1046	RW	kvarh Export of T4	INT32		
1048	RW	kVAh of T4	INT32		
1050	RW	kWh Import of T5	INT32	x0.01	kWh
1052	RW	kWh Export of T5	INT32		
1054	RW	kvarh Import of T5	INT32		
1056	RW	kvarh Export of T5	INT32		
1058	RW	kVAh of T5	INT32	x0.01	kVAh
1060	RW	kWh Import of T6	INT32		
1062	RW	kWh Export of T6	INT32		
1064	RW	kvarh Import of T6	INT32		
1066	RW	kvarh Export of T6	INT32	x0.01	kvarh
1068	RW	kVAh of T6	INT32		
1070	RW	kWh Import of T7	INT32		
1072	RW	kWh Export of T7	INT32		
1074	RW	kvarh Import of T7	INT32	x0.01	kvarh
1076	RW	kvarh Export of T7	INT32		
1078	RW	kVAh of T7	INT32		
1080	RW	kWh Import of T8	INT32		
1082	RW	kWh Export of T8	INT32	x0.01	kWh
1084	RW	kvarh Import of T8	INT32		
1086	RW	kvarh Export of T8	INT32		
1088	RW	kVAh of T8	INT32		

Table 5-22 Monthly Energy Log

Notes:

- 1) This register represents the Month when it is read. To read the Monthly Energy Log, this register must be first written to indicate to the PMC-350-C which log to load from memory. The range of this register is from 0 to 12, which represents the Present Month and the Last 12 Months. For example, if the current month is 2016/10, "0" means 2016/10, "1" means 2016/09, "2" means 2016/08, "12" means "2015/10".
- 2) For each Monthly Energy Log, the time stamp shows the exact self-read time (20YY/MM/DD HH:MM:SS) when the log was recorded. For the Monthly Energy Log of the Present Month, the time stamp shows the current time of the meter because the present month is not yet over.
- 3) The Monthly Energy Log for the Present Month can be modified, but the Monthly Energy Logs for the Last 12 Months are Read Only.

5.8 Daily and Monthly Freeze Logs

5.8.1 Daily Freeze Log

Register	Property	Description	Format	Scale	Unit
12000	RW	Index ¹	INT16	1 to 60	
12001	RO	High-order Byte: Year (0-99) Low-order Byte: Month (1-12)	INT16	-	
12002	RO	High-order Byte: Day (1-31) Low-order Byte: Hour (0-23)	INT16		
12003	RO	High-order Byte: Minute (0-59) Low-order Byte: Second (0-59)	INT16		
12004	RO	kWh Total	INT32	x0.01	kWh
12006	RO	kvarh Total	INT32		kvarh
12008	RO	kVAh Total	INT32		kVAh
12010	RO	Peak Demand of kW Total	Float	x1	W
12012	RO	Peak Demand of kvar Total	Float		var
12014	RO	Peak Demand of kVA Total	Float		VA
12016	RO	Setpoint 1 Active Duration	UINT32		S
12018	RO	Setpoint 2 Active Duration	UINT32		
...	RO	...	UINT32		
12034	RO	Setpoint 10 Active Duration	UINT32		

Table 5-23 Daily Freeze Log

Note:

- 1) Writing a value N between 1 and 60 to the **Index** register to retrieve the Daily Freeze Log of the Nth entry. For example, writing 1 to the **Index** register will retrieve yesterday's Daily Freeze Log. If N = 0 or N > 60, an exception response will be returned with the Illegal Data Value error code (0x03) as defined by the Modbus protocol. If all the returned values of the Nth Log Record (where 1 ≤ N ≤ 60) are all 0 (including the timestamp), this indicates that the returned Log Record is invalid and that the end of the Log has been reached. If the software is reading the Log for the very first time, it should start with N=1 and stop when either N=60 or when the returned Log Record is invalid. After that, all the software has to do is to read the Log on a daily basis with N=1.

5.8.2 Monthly Freeze Log

Register	Property	Description	Format	Scale	Unit
12500	RW	Index ¹	INT16	1 to 36	
12501	RO	High-order Byte: Year (0-99) Low-order Byte: Month (1-12)	INT16	-	
12502	RO	High-order Byte: Day (1-31) Low-order Byte: Hour (0-23)	INT16		
12503	RO	High-order Byte: Minute (0-59) Low-order Byte: Second (0-59)	INT16		
12504	RO	kWh Total	INT32	x0.01	kWh
12506	RO	kvarh Total	INT32		kvarh
12508	RO	kVAh Total	INT32		kVAh
12510~12515	RO	Peak Demand of kW Total	See Table 5-25		
12516~12521	RO	Peak Demand of kvar Total			
12522~12527	RO	Peak Demand of kVA Total			
12528	RO	Setpoint 1 Active Duration	UINT32	1	S
12530	RO	Setpoint 2 Active Duration	UINT32		
...	RO	...	UINT32		
12546	RO	Setpoint 10 Active Duration	UINT32		

Table 5-24 Monthly Freeze Log

Offset		Description
+0	High	Year - 2000
	Low	Month
+1	High	Day

	Low	Hour
+2	High	Minute
	Low	Second
+3	-	Millisecond
+4~+5	-	Peak Demand Value

Table 5-25 Demand Data Structure

Note:

- 1) Writing a value N between 1 and 36 to the **Index** register to retrieve the Monthly Freeze Log of the Nth entry. For example, writing 1 to the **Index** register will retrieve last month's Monthly Freeze Log. If N = 0 or N > 36, an exception response will be returned with the Illegal Data Value error code (0x03) as defined by the Modbus protocol. If all the returned values of the Nth Log Record (where 1 ≤ N ≤ 36) are all 0 (including the timestamp), this indicates that the returned Log Record is invalid and that the end of the Log has been reached. If the software is reading the Log for the very first time, it should start with N=1 and stop when either N=36 or when the returned Log Record is invalid. After that, all the software has to do is to read the Log on a monthly basis with N=1.

5.9 SOE Log

The SOE Log Pointer points to the register address within the SOE Log where the next event will be stored. The following formula is used to determine the register address of the most recent SOE event referenced by the SOE Log Pointer value:

$$\text{Register Address} = 10000 + \text{Modulo} (\text{SOE Log Pointer} - 1 / 100) * 8$$

Register	Property	Description	Format
10000~10007	RO	Event 1	See Table 5-27
10008~10015	RO	Event 2	
10016~10023	RO	Event 3	
10024~10031	RO	Event 4	
10032~10039	RO	Event 5	
10040~10047	RO	Event 6	
10048~10055	RO	Event 7	
10056~10063	RO	Event 8	
10064~10071	RO	Event 9	
10072~10079	RO	Event 10	
10080~10087	RO	Event 11	
10088~10095	RO	Event 12	
...		...	
10792~10799	RO	Event 100	

Table 5-26 SOE Log

Notes:

- 1) SOE Log Data Structure

Offset	Property	Description	Unit
+0	RO	Hi: Event Classification	See Table 5-28
	RO	Lo: Sub-Classification	
+1	RO	Hi: Year	0-99 (Year-2000)
	RO	Lo: Month	1 to 12
+2	RO	Hi: Day	1 to 31
	RO	Lo: Hour	0 to 23
+3	RO	Hi: Minute	0 to 59
	RO	Lo: Second	0 to 59
+4	RO	Millisecond	0 to 999
	RO	Hi: Reserved	-
+5	RO	Lo: Status ¹	-
	RO	Event Value ²	-
+6 to +7	RO		

Table 5-27 SOE Log Data Structure

Notes:

1. The return value "01" means DI Inactive/ DO Operated/Alarm (including Setpoint & Diagnosis)/Connection Fault; and the return value "00" means DI Active/ DO Released/Setpoint Return/Connection Restore.
2. The returned Event Value (for SOE Event Classification=Setpoint only) is in Float format, and please refer to **Table 5-35 Setpoint Parameters** to check the Unit for each parameter.

- 2) SOE Classification

Event Classification	Sub-Classification	Status	Event Value	Description
1=DI Changes	1	1/0		DI1 Inactive / DI1 Active
	2	1/0		DI2 Inactive / DI2 Active

CET Electric Technology

	3	1/0		DI3 Inactive / DI3 Active
	4	1/0		DI4 Inactive / DI4 Active
2=DO Changes	1	1/0		DO1 Operated/Released by Remote Control
	2	1/0		DO2 Operated/Released by Remote Control
	11	1/0		DO1 Operated/Released by Setpoint
	12	1/0		DO2 Operated/Released by Setpoint
3=Setpoint	1	1/0	Trigger Value/ Return Value	Over Uln Setpoint Active/Return
	2	1/0		Over Ull Setpoint Active/Return
	3	1/0		Over Current Setpoint Active/Return
	4	1/0		Over In Setpoint Active/Return
	5	1/0		Over Frequency Setpoint Active/Return
	6	1/0		Over kW Total Setpoint Active/Return
	7	1/0		Over kvar Total Setpoint Active/Return
	8	1/0		Over kVA Total Setpoint Active/Return
	9	1/0		Over PF Total Setpoint Active/Return
	10	1/0		Over kW Total Present Demand Setpoint Active/Return
	11	1/0		Over kvar Total Present Demand Setpoint Active/Return
	12	1/0		Over kVA Total Present Demand Setpoint Active/Return
	13	1/0		Over kW Total Predicted Demand Setpoint Active/Return
	14	1/0		Over kvar Total Predicted Demand Setpoint Active/Return
	15	1/0		Over kVA Total Predicted Demand Setpoint Active/Return
	16	1/0		Over Voltage THD Setpoint Active/Return
	17	1/0		Over Voltage TOHD Setpoint Active/Return
	18	1/0		Over Voltage TEHD Setpoint Active/Return
	19	1/0		Over Current THD Setpoint Active/Return
	20	1/0		Over Current TOHD Setpoint Active/Return
	21	1/0		Over Current TEHD Setpoint Active/Return
	22	1/0		Over Voltage Unbalance Setpoint Active/Return
	23	1/0		Over Current Unbalance Setpoint Active/Return
	24	1/0		Reversal Phase Setpoint Active/Return
	25	1/0		Over Ir Setpoint Active/Return
	26~27	1/0		Reserved
	28	1/0		Over TC1 Setpoint Active/Return
	29	1/0		Over TC2 Setpoint Active/Return
	30	1/0		Over TC3 Setpoint Active/Return
	31	1/0		Over TC4 Setpoint Active/Return
	32	1/0		Over Ia Setpoint Active/Return
	33	1/0		Over Ib Setpoint Active/Return
	34	1/0		Over Ic Setpoint Active/Return
	35	1/0		Over Uan Setpoint Active/Return
	36	1/0		Over Ubn Setpoint Active/Return
	37	1/0		Over Ucn Setpoint Active/Return
	38~40	1/0		Reserved
	41	1/0		Under Uln Setpoint Active/Return
	42	1/0		Under Ull Setpoint Active/Return
	43	1/0		Under Current Setpoint Active/Return
	44	1/0		Under In Setpoint Active/Return
	45	1/0		Under Frequency Setpoint Active/Return
	46	1/0		Under kW Total Setpoint Active/Return
	47	1/0		Under kvar Total Setpoint Active/Return
	48	1/0		Under kVA Total Setpoint Active/Return
	49	1/0		Under PF Total Setpoint Active/Return
	50	1/0		Under kW Total Present Demand Setpoint Active/Return
	51	1/0		Under kvar Total Present Demand Setpoint Active/Return
	52	1/0		Under kVA Total Present Demand Setpoint Active/Return

	53	1/0		Under kW Total Predicted Demand Setpoint Active/Return
	54	1/0		Under kvar Total Predicted Demand Setpoint Active/Return
	55	1/0		Under kVA Total Predicted Demand Setpoint Active/Return
	56	1/0		Under Voltage THD Setpoint Active/Return
	57	1/0		Under Voltage TOHD Setpoint Active/Return
	58	1/0		Under Voltage TEHD Setpoint Active/Return
	59	1/0		Under Current THD Setpoint Active/Return
	60	1/0		Under Current TOHD Setpoint Active/Return
	61	1/0		Under Current TEHD Setpoint Active/Return
	62	1/0		Under Voltage Unbalance Setpoint Active/Return
	63	1/0		Under Current Unbalance Setpoint Active/Return
	64	1/0		Under Ir Setpoint Active/Return
	65~66			Reserved
	67	1/0		Under TC1 Setpoint Active/Return
	68	1/0		Under TC2 Setpoint Active/Return
	69	1/0		Under TC3 Setpoint Active/Return
	70	1/0		Under TC4 Setpoint Active/Return
	71	1/0		Under Ia Setpoint Active/Return
	72	1/0		Under Ib Setpoint Active/Return
	73	1/0		Under Ic Setpoint Active/Return
	74	1/0		Under Uan Setpoint Active/Return
	75	1/0		Under Ubn Setpoint Active/Return
	76	1/0		Under Ucn Setpoint Active/Return
4=Self-diagnosis	1	1	0	System Parameter Fault
	2	1	0	Internal Parameter Fault
	3	1	0	TOU Parameter Fault
	4	1	0	Memory Fault
5=Operations	1	0	0	Power On
	2	0	0	Power Off
	3~29	0		Reserved
	30	0	0	Clear All Energy Registers via COM ¹
	31	0	0	Clear Present Monthly Energy Log via COM ²
	32	0	0	Clear Historical Monthly Energy log via COM ³
	33	0	0	Clear Peak Demand of This Month (Since Last Reset) via COM
	34	0	0	Clear All Demand Registers via COM ⁴
	35	0	0	Clear Max./Min. Logs of This Month via COM
	36	0	0	Clear All Max./Min. Logs via COM
	37	0	0	Clear All Data via COM ⁵
	38	0	0	Clear SOE Log via COM
	39	0	x=1~4	Clear DIx Pulse Counter via COM
	40	0	0	Clear All DI Pulse Counters via COM
	41	0	0	Clear Device Operating Time via COM
	42	0	0	Reserved
	43	0	0	Setup Changes via COM
	44	0	0	Preset Energy Value via COM
	45	0	0	Setup TOU Energy via COM
	46	0	1~4	Switch TOU Schedule ⁶
47	0	0	Clear Daily Freeze Log via COM	
48	0	0	Clear Monthly Freeze Log via COM	
49	0	1~5	Clear DRx Log via COM	
50	0	0	Clear All DR logs via COM	
6= Connection	1	1/0	1	Residual CT Fault/Restore
	2	1/0	1~4	RTDx Probe Fault/Restore

Table 5-28 SOE Classification

Notes:

1. Clear All Energy Registers via COM means to clear the 3-Ø Total and Per-Phase energy registers (including TOU Energy).
2. Clear Present Monthly Energy Log via COM means to clear the Monthly Energy Log of the Present Month.
3. Clear Historical Monthly Energy Log via COM means to clear Monthly Energy Log of the last 1 to 12 months, excluding the Monthly Energy Log for the Present Month.

4. **Clear All Demand Registers via COM** means to clear the Present/Predicated Demands and Peak Demand Log of This Month (Since Last Reset) and Last Month (Before Last Reset).
5. **Clear All Data via COM** means to clear All Energy Registers, Monthly Energy Log, Demand Registers, Max. & Min. Logs, SOE Logs, DI Counters, DR Logs, Daily and Monthly Freeze Logs, Setpoint Active Duration and Frequency and Device Operating Time.
6. The event values of **Switch TOU Schedule** are illustrated in the table below:

Record Value	Description
1	Switch Schedule 1 to Schedule 2 manually
2	Switch Schedule 2 to Schedule 1 manually
3	Switch Schedule 1 to Schedule 2 automatically
4	Switch Schedule 2 to Schedule 1 automatically

Table 5-29 TOU Switch Record

5.10 Data Recorder Log

Register	Property	Description	Format
20000~20037	RO	DR Log #1 Buffer	See Table 5-31
20038~20075	RO	DR Log #2 Buffer	
20076~20113	RO	DR Log #3 Buffer	
20114~20151	RO	DR Log #4 Buffer	
20152~20189	RO	DR Log #5 Buffer	

Table 5-30 Data Recorder Log

Offset	Property	Description	Format
+0	RW	DR Log X Pointer	UINT32
+2	RO	High-order Byte: Year (0-99) Low-order Byte: Month (1-12)	UINT16
+3	RO	High-order Byte: Day (1-31) Low-order Byte: Hour (0-23)	UINT16
+4	RO	High-order Byte: Minute (0-59) Low-order Byte: Second (0-59)	UINT16
+5	RO	Millisecond	UINT16
+6~+7	RO	Parameter #1	See Appendix A Data Recorder Parameter List
+8~+9	RO	Parameter #2	
...		...	
+36~+37	RO	Parameter #16	

Table 5-31 DR Data Buffer Structure

Notes:

- 1) Writing n to the **DR Log X Pointer** register will load the Log Record at pointer position n into the DR Log X Buffer from the device's memory.
- 2) Writing a pointer value that points to a Log Record that is either already expired or has not been generated yet to the **DR Log X Pointer** register will generate an exception response with the Illegal Data Value error code (0x03) as defined by the Modbus protocol.

5.11 Device Setup

5.11.1 Basic Setup

Register	Property	Description	Format	Range, Default*
6000	RW	PT Primary ¹	UINT32	1 to 1,000,000V, 100*
6002	RW	PT Secondary	UINT32	1 to 690V, 100*
6004	RW	CT Primary ²	UINT32	1 to 30,000A, 5*
6006	RW	CT Secondary ²	UINT32	1 to 5A, 5*
6008	RW	SCCT Type ³	UINT32	1=100A*, 2=200A, 3=400A, 4=800A, 5~6: Reserved, 7=1600A
6010~6018	RW	Reserved	UINT32	-
6020	RW	Wiring Mode	UINT16	0=DEMO, 1=1P2W L-N 2=1P2W L-L, 3=1P3W 4=3P3W, 5=3P4W*, 6=3P3W_2CT
6021	RW	Power Factor Convention	UINT16	0=IEC*, 1=IEEE, 2=-IEEE
6022	RW	kVA Calculation	UINT16	0=Vector*, 1=Scalar
6023	RW	Ia Polarity	UINT16	0=Normal*, 1=Reverse
6024	RW	Ib Polarity	UINT16	
6025	RW	Ic Polarity	UINT16	
6026~6027	RW	Reserved	UINT16	-

6028	RW	THD Calculation ⁴	UINT16	0= THDf*, 1= THDr
6029	RW	Demand Period ⁵	UINT16	1 to 60 (minutes), 15*
6030	RW	No. of Sliding Windows	UINT16	1 to 15, 1*
6031	RW	Predicted Response	UINT16	70 to 99, 70*
6032	RW	Arm before Execute	UINT16	0=Disabled*, 1=Enabled
6033	RW	Self-Read Time ⁶	UINT16	Default=0xFFFF
6034	RW	Monthly Energy Log Self-Read Time ⁷	UINT16	0*
6035	RW	Energy Pulse Constant	UINT16	0=10 imp/kxh 1=100 imp/kxh*, 2=1000 imp/kxh, 3=3200 imp/kxh
6036~6040	RW	Reserved	UINT16	-
6041	RW	Monthly Freeze Self-Read Time ⁸	UINT16	0*
6042	RW	Daily Freeze Self-Read Time ⁹	UINT16	0*

Table 5-32 Basic Setup Parameters

Notes:

1. The ratio between PT Primary and PT Secondary cannot exceed 10,000.
2. **CT Primary** and **CT Secondary** registers are only valid when the meter ordered with 5A/2mA SCCTA, where the **CT Primary/Secondary** ratio refers to the Primary Side CT.
3. The **SCCT Type** register determines the CT Primary/Secondary ratio for the meter ordered with 100A, 200A, 400A, 800A and 1600A SCCT, which are 100A/100A, 200A/100A, 400A/100A, 800A/100A and 1600A/100A respectively.
4. There are two ways to calculate **THD**:

THDf:

$$THDf = \frac{\sqrt{\sum_{n=2}^{\infty} I_n^2}}{I_1} \times 100\%$$

where I_1 represents the RMS value of the fundamental component, and I_n represents the RMS value for the n^{th} harmonic with n for harmonic order.

THDr:

$$THDr = \frac{\sqrt{\sum_{n=2}^{\infty} I_n^2}}{\sqrt{\sum_{n=1}^{\infty} I_n^2}} \times 100\%$$

where I_n represents the RMS value for the n^{th} harmonic with n for harmonic order.

5. The Present/Predicted Demand will be reset once the **Demand Period/No. of Sliding Windows (Predicted Response excluded)** is changed.
6. The **Self-Read Time** applies to both the Peak Demand Log as well as the Max./Min. Log and supports the following three options:
 - A zero value means that the Self-Read will take place at 00:00 of the first day of each month.
 - A non-zero value means that the Self-Read will take place at a specific time and day based on the formula: Self-Read Time = Day x 100 + Hour where $0 \leq \text{Hour} \leq 23$ and $1 \leq \text{Day} \leq 28$. For example, the value 1512 means that the Self-Read will take place at 12:00pm on the 15th day of each month.
 - A 0xFFFF value means the automatic self-read operation is disabled and the log will be transferred manually
7. The **Monthly Energy Log Self-Read Time** supports only two options:
 - A zero value means that the Self-Read will take place at 00:00 of the first day of each month.
 - A non-zero value means that the Self-Read will take place at a specific time and day based on the formula: Self-Read Time = Day * 100 + Hour where $0 \leq \text{Hour} \leq 23$ and $1 \leq \text{Day} \leq 28$. For example, the value 1512 means that the Self-Read will take place at 12:00pm on the 15th day of each month.
8. The **Monthly Freeze Self-Read Time** supports only two options:
 - A zero value means that the Self-Read will take place at 00:00 of the first day of each month.
 - A non-zero value means that the Self-Read will take place at a specific time and day based on the formula: Self-Read Time = Day * 100 + Hour where $0 \leq \text{Hour} \leq 23$ and $1 \leq \text{Day} \leq 28$. For example, the value 1512 means that the Self-Read will take place at 12:00pm on the 15th day of each month.
9. The **Daily Freeze Self-Read Time** can be set to a zero value or a non-zero value:
 - A zero value means that the Self-Read will take place at 00:00 everyday.
 - A non-zero value means that the Self-Read will take place at a specific time of the day based on the formula: Self-Read time = (Hour x 100 + Min) where $0 \leq \text{Hour} \leq 23$ and $0 \leq \text{Min} \leq 59$. For example, the value 1512 means that the Self-Read will take place at 15:12 of each day.

5.11.2 I/O Setup

Register	Property	Description	Format	Range, Default*
6200	RW	DI1 Function	UINT16	0 = Digital Input*, 1=Pulse Counting
6201	RW	DI2 Function	UINT16	
6202	RW	DI3 Function	UINT16	
6203	RW	DI4 Function	UINT16	
6204~6207	RW	Reserved	UINT16	-
6208	RW	DI1 Debounce	UINT16	1 to 9999 ms, 20*
6209	RW	DI2 Debounce	UINT16	
6210	RW	DI3 Debounce	UINT16	
6211	RW	DI4 Debounce	UINT16	
6212~6215	RW	Reserved	UINT16	-
6216	RW	DI1 Pulse Weight ¹	UINT32	1* to 1000000
6218	RW	DI2 Pulse Weight ¹	UINT32	
6220	RW	DI3 Pulse Weight ¹	UINT32	
6222	RW	DI4 Pulse Weight ¹	UINT32	
6224~6231	RW	Reserved	UINT32	-
6232	RW	DO1 Mode ²	UINT16	0= Digital Output, 1= kWh Import 2= kWh Export, 3= kWh Total* 4= kvarh Import, 5= kvarh Export 6= kvarh Total
6233	RW	DO2 Mode ²	UINT16	
6234~6235	RW	Reserved	UINT16	-
6236	RW	DO1 Pulse Width	UINT16	0 to 6000 (x0.1s), 10* (0 = Latch Mode)
6237	RW	DO2 Pulse Width	UINT16	
6238~6247	RW	Reserved	UINT16	-
6248	RW	RTD 1 Compensation	UINT16	0 to 2000 (x0.01Ω), 0*
6249	RW	RTD 2 Compensation	UINT16	0 to 2000 (x0.01Ω), 0*
6250	RW	RTD 3 Compensation	UINT16	0 to 2000 (x0.01Ω), 0*
6251	RW	RTD 4 Compensation	UINT16	0 to 2000 (x0.01Ω), 0*

Table 5-33 I/O Setup Parameters

Notes:

1. DIx Counter= Pulse Counter × DIx Pulse Weight.
2. DOx Mode register is valid when the meter is equipped with SS Relay State Output.

5.11.3 Setpoint Setup

Register	Property	Description	Format	Range, Default*
6500	RW	Setpoint #1	Setpoint Type	UINT16 0=Disabled* 1=Over Setpoint 2=Under Setpoint
6501	RW		Parameters ¹	UINT16 0 to 37 0=None*
6502	RW		Over Limit	Float 999,999*
6504	RW		Under Limit	Float 0*
6506	RW		Active Delay	UINT16 0* to 9999 s
6507	RW		Inactive Delay	UINT16 0* to 9999 s
6508	RW		Trigger Action 1	UINT16 0 to 2
6509	RW		Trigger Action 2	UINT16 0 to 2
...	
6590	RW	Setpoint #10	Setpoint Type	UINT32 0=Disabled* 1=Over Setpoint 2=Under Setpoint
6591	RW		Parameter ¹	UINT16 0* to 37
6592	RW		Over Limit	Float 999,999*
6594	RW		Under Limit	Float 0*
6596	RW		Active Delay	UINT16 0* to 9999 s
6597	RW		Inactive Delay	UINT16 0* to 9999 s
6598	RW		Trigger Action 1	UINT16 0 to 2
6599	RW		Trigger Action 2	UINT16 0 to 2

Table 5-34 Setpoint Setup

Notes:

- 1) The table below illustrates the Setpoint Parameters.

Key	Setpoint Parameter	Scale	Resolution	Unit
0	None	-	-	-
1	Uln (Any Phase Voltage)	x1	0.01	V

2	UII (Any Line Voltage)			
3	I (Any Phase Current)		0.001	A
4	In (Calculated)			
5	Frequency		0.01	Hz
6	P (kW Total)			W
7	Q (kvar Total)			var
8	S (kVA Total)			VA
9	PF (PF Total)			-
10	P Pres. DMD (kW Total Present Demand)		0.001	W
11	Q Pres. DMD (kvar Total Present Demand)			var
12	S Pres. DMD (kVA Total Present Demand)			VA
13	P Pred. DMD (kW Total Predicted Demand)			W
14	Q Pred. DMD (kvar Total Predicted Demand)			var
15	S Pred. DMD (kVA Total Predicted Demand)			VA
16	U THD		0.001%	100%
17	U TOHD			100%
18	U TEHD			100%
19	I THD			100%
20	I TOHD			100%
21	I TEHD			100%
22	U Unbal. (Voltage Unbalance)			100%
23	I Unbal. (Current Unbalance)			100%
24	Reversal (Phase Reversal) ¹	-	-	-
25	IR (Residual Current)*	x1	1	mA
26-27	Reserved	-	-	-
28	TC1*			
29	TC2*		0.1	°C
30	TC3*			
31	TC4*			
32	I1	x1	0.001	A
33	I2			
34	I3			
35	Uan		0.01	V
36	Ubn			
37	Ucn			

* Appears only if the device is equipped with the appropriate option.

Table 5-35 Setpoint Parameters

Notes:

- When **Reversal** is set as the **Setpoint Parameter**, the **Setpoint Type** should be set to 1 (i.e., Over Setpoint). The **Setpoint Type=2** (i.e., Under Setpoint) is invalid. In addition, the **Over Limit** should be set as 0 and **Under Limit** should be as 1.

5.11.4 Comm. Setup

Register	Property	Description	Format	Range, Default*
6400	RW	Serial Port Protocol	UINT16	0=Modbus RTU*
6401	RW	Unit ID	UINT16	1 to 247, 100*
6402	RW	Baud Rate ¹	UINT16	0=1200, 1=2400, 2=4800, 3=9600*, 4=19200, Others=Reserved
6403	RW	Comm. Config.	UINT16	0=8N2, 1=8O1, 2=8E1* 3=8N1, 4=8O2, 5=8E2

Table 5-36 Communication Setup

Notes:

- If the **Baud Rate** is set to an invalid value, it will default to 9600bps automatically.

5.11.5 LoRaWAN Setup

Register	Property	Description	Format	Range, Default*
6300~6307	RW	LoRaWAN AppEUI	UINT16	See Note 1
6308~6323	RW	LoRaWAN AppKEY	UINT16	
6324~6331	RO	LoRaWAN DevEUI	UINT16	
6332	RW	LoRaWAN ADR ²	UINT16	0=Disabled, 1=Enabled*
6333	RW	LoRaWAN Power ³	UINT16	0=20dBm* 1=17dBm 2=16dBm 3=14dBm 4=12dBm 5=10dBm 6=7dBm 7=5dBm

				8=2dBm
6334	RW	LoRaWAN Datarate ³	UINT16	0=SF12, 1=SF11, 2=SF10, 3=SF9, 4=SF8, 5=SF7*
6335	RW	LoRaWAN Class	UINT16	0=Class A, 1=Class C*
6336	RW	LoRaWAN TransCnt	UINT16	1~8, 8*
6334~6349	RW	Reserved	UINT16	-
6350	RW	Auto-Push Config.	UINT32	See Note 4
6352	RW	Energy & DMD Data Push Interval	UINT16	1~1440 (mins), 15*
6353	RW	Real-time Measurement Data Push Interval	UINT16	1~1440 (mins), 15*
6354	RW	Power Quality Data Push Interval	UINT16	1~1440 (mins), 15*
6355	RW	Max./Min. Data Push Delay	UINT16	1~3600 (s), 60*

Table 5-37 LoRaWAN Setup

Notes:

1. The **LoRaWAN AppEUI** (Application Identifier), **LoRaWAN AppKEY** (Application AES-128 Key) and **LoRaWAN DevEUI** (Global Unique Node ID in IEEE EUI64 address) are used for the activation of the meter via Over-The-Air-Activation (OTAA) when it is deployed or reset.
2. It's recommended to enable the **LoRaWAN ADR** (Adaptive Data Rate) so that the LoRaWAN Network infrastructure can manage the data rate and power for meter, which will optimize the network capacity and battery lifetime.
3. When **LoRaWAN ADR** is enabled, the **LoRaWAN Power** register is invalid since the transmission power and data rate of the LoRaWAN meter would be adjusted by the network infrastructure.
4. The following table illustrates the **Auto-Push Config.** register, with "1" meaning Enabled and "0" meaning Disabled.

B31	B30	B29	B28
I/O Status	Monthly Freeze Log	Daily Freeze Log	Reserved
B27	B26	B2	B24
Reserved	Reserved	Reserved	Reserved
B23	B22	B21	B20
Reserved	Reserved	Reserved	Reserved
B19	B18	B17	B16
Min. K-Factor/Crest Factor	Max. K-factor/Crest Factor	Min. Current TDD	Max. Current TDD
B15	B14	B13	B12
Min. Harmonic	Max. Harmonic	Min. Ir/Temperature	Max. Ir/Temperature
B11	B10	B9	B8
Min. Power/Freq./PF	Max. Power/Freq./PF	Min. Voltage/Current	Max. Voltage/Current
B7	B6	B5	B4
Peak Demand	Reserved	Reserved	Basic PQ
B3	B2	B1	B0
Harmonics	Ir and Temp.	Basic Measurements	Energy and Demand

Table 5-38 Data Push Config. Register

If B0 is set to 1, the corresponding data will be auto-pushed based on the **Energy & Dmd Data Push Interval**.
 If B1-B2 is set to 1, the corresponding data will be auto-pushed based on the **Real-time Measurement Data Push Interval**.
 If B3-B4 is set to 1, the corresponding data will be auto-pushed based on the **Power Quality Data Push Interval**.
 If B7-B19 is set to 1, the corresponding data will be auto-pushed if there is a new maximum or minimum value achieved and after the **Max./Min. Data Push Delay** has expired.
 If B29-B30 is set to 1, the corresponding Freeze Log will be auto-pushed when there is a new log generated.
 If B31 is set to 1, the I/O status will be auto-pushed whenever there is a valid change of State.

5.11.6 Data Recorder Setup

Register	Property	Description	Format
6600~6623	RW	Data Recorder #1*	See Table 5-40 Data Recorder Structure
6624~6647	RW	Data Recorder #2*	
6648~6671	RW	Data Recorder #3*	
6672~6695	RW	Data Recorder #4*	
6696~6719	RW	Data Recorder #5*	

* Please refer to **Appendix B Data Recorder Default Settings** for the default configuration of the Data Recorders.

Table 5-39 Data Recorder Setup

Offset	Property	Description	Format	Range
+0	RW	Trigger Mode	UINT16	0=Disabled 1=Triggered by Timer

+1	RW	Recording Mode ¹	UINT16	0=Stop-when-Full 1=First-In-First-Out
+2	RW	Recording Depth ¹	UINT32	0 to 10,000
+4	RW	Recording Interval ¹	UINT32	60 to 3,456,000 s
+6	RW	Recording Offset ²	UINT16	0 to 43,200 s
+7	RW	Number of Parameters ¹	UINT16	0 to 16
+8	RW	Parameter #1 ¹	UINT16	Please refer to Appendices A and B for a complete list of the Data Recorder Parameters and the default configuration for each DR, respectively.
+9	RW	Parameter #2 ¹	UINT16	
+10	RW	Parameter #3 ¹	UINT16	
...	RW	...	UINT16	
+23	RW	Parameter #16 ¹	UINT16	

Table 5-40 Data Recorder Structure

Notes:

- 1) Changing any of these Data Recorder setup registers will reset the Data Recorder.
- 2) **Recording Offset** can be used to delay the recording by a fixed amount of time from the **Recording Interval**. For example, if the **Recording Interval** is set to 3600 (hourly) and the **Recording Offset** is set to 300 (5 minutes), the recording will take place at 5 minutes after the hour every hour, i.e. 00:05, 01:05, 02:05...etc. The value of the **Recording Offset** parameter should be less than the **Recording Interval** parameter.
- 3) Please refer to **Appendix A Data Recorder Parameter List** for a complete list of Data Recorder Parameters.
- 4) The following table illustrates different types of Data Recorder parameters.

Type	Scale	Format	Unit
Voltage	1	Float	V
Current			A
Power			W/var/VA
PF			None
Frequency			Hz
Unbalance			100%
THD			100%
Temperature			×10 °C
DI Counter	10	UINT32	None
kWh/kvarh/kVAh		INT32	0.01 kWh/kvarh/kVAh

Table 5-41 Different Types of Data Recorder Parameters

5.12 TOU Setup

5.12.1 Basic

Register	Property	Description	Format	Range/Option
7000	RO	Current Tariff ¹	UINT16	0=T1, 1=T2, 2=T3, 3=T4 4=T5, 5=T6, 6=T7, 7=T8
7001	RO	Current Season	UINT16	0 to 11 (Season #1 to #12)
7002	RO	Current Period	UINT16	0 to 11 (Period #1 to #12)
7003	RO	Current Daily Profile No.	UINT16	0 to 19 (Daily Profile #1 to #20)
7004	RO	Current Day Type	UINT16	0=Weekday1, 1=Weekday2 2=Weekday3, 3= Alternate Day
7005	RO	Current TOU No.	UINT16	0=TOU #1, 1=TOU #2
7006	RW	TOU Switch Time	UINT32	See Note 1)
7008	WO	Switch TOU Manually	UINT16	Write 0xFF00 to manually switch the TOU schedules
7009	RW	Sunday Setup	UINT16	0=Weekday1*, 1=Weekday2 2=Weekday3
7010	RW	Monday Setup	UINT16	
7011	RW	Tuesday Setup	UINT16	
7012	RW	Wednesday Setup	UINT16	
7013	RW	Thursday Setup	UINT16	
7014	RW	Friday Setup	UINT16	
7015	RW	Saturday Setup	UINT16	

Table 5-42 TOU Basic Setup

Notes:

- 1) The following table illustrates the data structure for the TOU Switch Time. For example, 0x1003140C indicates a switch time of 12:00pm on March 20th, 2016. Writing 0xFFFFFFFF to this register disables the switching between TOU schedules.

Byte 3	Byte 2	Byte 1	Byte 0
Year-2000 (0-37)	Month (1-12)	Day (1-31)	Hour (00-23)

Table 5-43 TOU Switch Time Format

5.12.2 Season

The PMC-350-C has two sets of Season setup parameters, one for each TOU. The Base Addresses for the two sets are 7100 and 8100, respectively, where the Register Address = Base Address + Offset. For example, the register address for TOU #1's Season #2's Start Date is 7100+4 = 7104.

Offset	Property	Description	Format	Range/Note
0	RW	Season #1: Start Date ¹	UINT16	0x0101
1	RW	Season #1: Weekday#1 Daily Profile	UINT16	0 to 19
2	RW	Season #1: Weekday#2 Daily Profile	UINT16	
3	RW	Season #1: Weekday#3 Daily Profile	UINT16	
4	RW	Season #2: Start Date	UINT16	High-order Byte: Month Low-order Byte: Day
5	RW	Season #2: Weekday#1 Daily Profile	UINT16	0 to 19
6	RW	Season #2: Weekday#2 Daily Profile	UINT16	
7	RW	Season #2: Weekday#3 Daily Profile	UINT16	
8	RW	Season #3: Start Date	UINT16	See Season #2: Start Date
9	RW	Season #3: Weekday#1 Daily Profile	UINT16	0 to 19
10	RW	Season #3: Weekday#2 Daily Profile	UINT16	
11	RW	Season #3: Weekday#3 Daily Profile	UINT16	
12	RW	Season #4: Start Date	UINT16	See Season #2: Start Date
13	RW	Season #4: Weekday#1 Daily Profile	UINT16	0 to 19
14	RW	Season #4: Weekday#2 Daily Profile	UINT16	
15	RW	Season #4: Weekday#3 Daily Profile	UINT16	
16	RW	Season #5: Start Date	UINT16	See Season #2: Start Date
17	RW	Season #5: Weekday#1 Daily Profile	UINT16	0 to 19
18	RW	Season #5: Weekday#2 Daily Profile	UINT16	
19	RW	Season #5: Weekday#3 Daily Profile	UINT16	
20	RW	Season #6: Start Date	UINT16	See Season #2: Start Date
21	RW	Season #6: Weekday#1 Daily Profile	UINT16	0 to 19
22	RW	Season #6: Weekday#2 Daily Profile	UINT16	
23	RW	Season #6: Weekday#3 Daily Profile	UINT16	
24	RW	Season #7: Start Date	UINT16	See Season #2: Start Date
25	RW	Season #7: Weekday#1 Daily Profile	UINT16	0 to 19
26	RW	Season #7: Weekday#2 Daily Profile	UINT16	
27	RW	Season #7: Weekday#3 Daily Profile	UINT16	
28	RW	Season #8: Start Date	UINT16	See Season #2: Start Date
29	RW	Season #8: Weekday#1 Daily Profile	UINT16	0 to 19
30	RW	Season #8: Weekday#2 Daily Profile	UINT16	
31	RW	Season #8: Weekday#3 Daily Profile	UINT16	
32	RW	Season #9: Start Date	UINT16	See Season #2: Start Date
33	RW	Season #9: Weekday#1 Daily Profile	UINT16	0 to 19
34	RW	Season #9: Weekday#2 Daily Profile	UINT16	
35	RW	Season #9: Weekday#3 Daily Profile	UINT16	
36	RW	Season #10: Start Date	UINT16	See Season #2: Start Date
37	RW	Season #10: Weekday#1 Daily Profile	UINT16	0 to 19
38	RW	Season #10: Weekday#2 Daily Profile	UINT16	
39	RW	Season #10: Weekday#3 Daily Profile	UINT16	
40	RW	Season #11: Start Date	UINT16	See Season #2: Start Date
41	RW	Season #11: Weekday#1 Daily Profile	UINT16	0 to 19
42	RW	Season #11: Weekday#2 Daily Profile	UINT16	
43	RW	Season #11: Weekday#3 Daily Profile	UINT16	
44	RW	Season #12: Start Date	UINT16	See Season #2: Start Date
45	RW	Season #12: Weekday#1 Daily Profile	UINT16	0 to 19
46	RW	Season #12: Weekday#2 Daily Profile	UINT16	
47	RW	Season #12: Weekday#3 Daily Profile	UINT16	

Table 5-44 Season Setup

Notes:

- 1) **Start Date** for Season #1 is Jan. 1st and cannot be modified.
- 2) Setting a Season's **Start Date** as 0xFFFF terminates the TOU's Season settings. All subsequent Seasons' setup parameters will be ignored since the previous Season's duration is from its **Start Date** to the end of the year.
- 3) The **Start Date** of a particular Season must be later than the previous Season's.

5.12.3 Daily Profile

The PMC-350-C has two sets of Daily Profile setup parameters, one for each TOU.

Register Address	Property	Description	Format
7200~7223	RW	Daily Profile #1	See Table 5-47
7224~7247	RW	Daily Profile #2	
7248~7271	RW	Daily Profile #3	
7272~7295	RW	Daily Profile #4	
7296~7319	RW	Daily Profile #5	
7320~7343	RW	Daily Profile #6	
7344~7367	RW	Daily Profile #7	
7368~7391	RW	Daily Profile #8	
7392~7415	RW	Daily Profile #9	
7416~7439	RW	Daily Profile #10	
7440~7463	RW	Daily Profile #11	
7464~7487	RW	Daily Profile #12	
7488~7511	RW	Daily Profile #13	
7512~7535	RW	Daily Profile #14	
7536~7559	RW	Daily Profile #15	
7560~7583	RW	Daily Profile #16	
7584~7607	RW	Daily Profile #17	
7608~7631	RW	Daily Profile #18	
7632~7655	RW	Daily Profile #19	
7656~7679	RW	Daily Profile #20	

Table 5-45 TOU #1's Daily Profile Setup

Register Address	Property	Description	Format
8200~8223	RW	Daily Profile #1	See Table 5-47
8224~8247	RW	Daily Profile #2	
8248~8271	RW	Daily Profile #3	
8272~8295	RW	Daily Profile #4	
8296~8319	RW	Daily Profile #5	
8320~8343	RW	Daily Profile #6	
8344~8367	RW	Daily Profile #7	
8368~8391	RW	Daily Profile #8	
8392~8415	RW	Daily Profile #9	
8416~8439	RW	Daily Profile #10	
8440~8463	RW	Daily Profile #11	
8464~8487	RW	Daily Profile #12	
8488~8511	RW	Daily Profile #13	
8512~8535	RW	Daily Profile #14	
8536~8559	RW	Daily Profile #15	
8560~8583	RW	Daily Profile #16	
8584~8607	RW	Daily Profile #17	
8608~8631	RW	Daily Profile #18	
8632~8655	RW	Daily Profile #19	
8656~8679	RW	Daily Profile #20	

Table 5-46 TOU #2's Daily Profile Setup

Offset	Property	Description	Format	Note	
+0	RW	Period #1 Start Time	UINT16	0x0000	
+1	RW	Period #1 Tariff	UINT16	0=T1, ..., 7=T8	
+2	RW	Period #2 Start Time	High-order Byte: Hour	UINT16	0 ≤ Hour < 24
			Low-order Byte: Min		
+3	RW	Period #2 Tariff	UINT16	0=T1, ..., 7=T8	
+4	RW	Period #3 Start Time	UINT16	See Period #2 Start Time	
+5	RW	Period #3 Tariff	UINT16	0=T1, ..., 7=T8	
+6	RW	Period #4 Start Time	UINT16	See Period #2 Start Time	
+7	RW	Period #4 Tariff	UINT16	0=T1, ..., 7=T8	
+8	RW	Period #5 Start Time	UINT16	See Period #2 Start Time	
+9	RW	Period #5 Tariff	UINT16	0=T1, ..., 7=T8	
+10	RW	Period #6 Start Time	UINT16	See Period #2 Start Time	
+11	RW	Period #6 Tariff	UINT16	0=T1, ..., 7=T8	
+12	RW	Period #7 Start Time	UINT16	See Period #2 Start Time	
+13	RW	Period #7 Tariff	UINT16	0=T1, ..., 7=T8	
+14	RW	Period #8 Start Time	UINT16	See Period #2 Start Time	

+15	RW	Period #8 Tariff	UINT16	0=T1, ..., 7=T8
+16	RW	Period #9 Start Time	UINT16	See Period #2 Start Time
+17	RW	Period #9 Tariff	UINT16	0=T1, ..., 7=T8
+18	RW	Period #10 Start Time	UINT16	See Period #2 Start Time
+19	RW	Period #10 Tariff	UINT16	0=T1, ..., 7=T8
+20	RW	Period #11 Start Time	UINT16	See Period #2 Start Time
+21	RW	Period #11 Tariff	UINT16	0=T1, ..., 7=T8
+22	RW	Period #12 Start Time	UINT16	See Period #2 Start Time
+23	RW	Period #12 Tariff	UINT16	0=T1, ..., 7=T8

Table 5-47 Daily Profile Data Structure

Notes:

- 1) **Daily Profile #1's Period #1 Start Time** is always 00:00 and cannot be modified.
- 2) Setting a Period's **Start Time** as 0xFFFF terminates the Daily Profile's settings. All later Daily Profile' setup parameters will be ignored, and the previous Period's duration is from its **Start Time** to the end of the day.
- 3) The minimum interval of a period is 15 minutes.
- 4) The **Start Time** of a particular Period must be later than the previous Period's.

5.12.4 Alternate Days

Each Alternate Day is assigned a Daily Profile and has a higher priority than Season. If a particular date is set as an Alternate Day, its assigned Daily Profile will override the "normal" Daily Profile for this day according to the TOU settings.

The PMC-350-C has two sets of Alternate Days setup parameters, one for each TOU. The Base Addresses for the two sets are 7700 and 8700, respectively, where the Register Address = Base Address + Offset. For example, the register address for TOU #2's Alternative Day #2's Date is 8700+3 = 8703.

Offset	Property	Description	Format	Note
0	RW	Alternate Day #1 Date ¹	UINT32	See Table 5-49
2	RW	Alternate Day #1 Daily Profile	UINT16	0 to 19
3	RW	Alternate Day #2 Date ¹	UINT32	See Table 5-49
5	RW	Alternate Day #2 Daily Profile	UINT16	0 to 19
6	RW	Alternate Day #3 Date ¹	UINT32	See Table 5-49
8	RW	Alternate Day #3 Daily Profile	UINT16	0 to 19
9	RW	Alternate Day #4 Date ¹	UINT32	See Table 5-49
11	RW	Alternate Day #4 Daily Profile	UINT16	0 to 19
12	RW	Alternate Day #5 Date ¹	UINT32	See Table 5-49
14	RW	Alternate Day #5 Daily Profile	UINT16	0 to 19
...	RW	...	UINT32	...
...	RW	...	UINT16	...
255	RW	Alternate Day #86 Date ¹	UINT32	See Table 5-49
256	RW	Alternate Day #86 Daily Profile	UINT16	0 to 19
258	RW	Alternate Day #87 Date ¹	UINT32	See Table 5-49
260	RW	Alternate Day #87 Daily Profile	UINT16	0 to 19
261	RW	Alternate Day #88 Date ¹	UINT32	See Table 5-49
263	RW	Alternate Day #88 Daily Profile	UINT16	0 to 19
264	RW	Alternate Day #89 Date ¹	UINT32	See Table 5-49
266	RW	Alternate Day #89 Daily Profile	UINT16	0 to 19
267	RW	Alternate Day #90 Date ¹	UINT32	See Table 5-49
269	RW	Alternate Day #90 Daily Profile	UINT16	0 to 19

Table 5-48 Alternate Days Setup

Notes:

- 1) The following table illustrates the data structure for the Date register:

Byte 3	Byte 2	Byte 1	Byte 0
Reserved	Year-2000 (0-37)	Month (1-12)	Day (1-31)

Table 5-49 Date Format

When the Year and/or Month are set as 0xFF, it means the Alternate Day is repetitive by year and/or month, i.e. the same day of every year or every month is an Alternate Day.

5.13 Time

There are two sets of Time registers supported by the PMC-350-C – Year/Month/Day/Hour/Minute/Second (Register # 60000 to 60002) and UNIX Time (Register # 60004). When sending time to the PMC-350-C over Modbus communications, care should be taken to only write one of the two Time register

sets. All registers within a Time register set must be written in a single transaction. If registers 60000 to 60004 are being written to at the same time, both Time register sets will be updated to reflect the new time specified in the UNIX Time register set (60004) and the time specified in registers 60000-60002 will be ignored. Writing to the Millisecond register (60003) is optional during a Time Set operation. When broadcasting time, the function code must be set to 0x10 (Pre-set Multiple Registers). Incorrect date or time values will be rejected by the meter. In addition, attempting to write a Time value less than Jan 1, 2000 00:00:00 will be rejected.

Register	Property	Description	Format	Note
60000	9000	RW	High-order Byte: Year	0-37 (Year-2000)
			Low-order Byte: Month	1 to 12
60001	9001	RW	High-order Byte: Day	1 to 31
			Low-order Byte: Hour	0 to 23
60002	9002	RW	High-order Byte: Minute	0 to 59
			Low-order Byte: Second	0 to 59
60003	9003	RW	Millisecond	0 to 999
60004 60005	9004 9005	RW	UNIX Time	UINT32 This time shows the number of seconds since 00:00:00 January 1, 1970

Table 5-50 Time Registers

5.14 Remote Control

The DO Control registers are implemented as both “Write-Only” Modbus Coil Registers (0XXXXX) and Modbus Holding Registers (4XXXXX), which can be controlled with the Force Single Coil command (Function Code 0x05) or the Preset Multiple Hold Registers (Function Code 0x10). The PMC-53A-E does not support the Read Coils command (Function Code 0x01) because DO Control registers are “Write-Only”. The DO Status register 0098 should be read instead to determine the current DO status.

The PMC-350-C adopts the ARM before EXECUTE operation for the remote control of its Digital Outputs if this function is enabled through the **Arm Before Execute Enable** Setup register (6032), which is disabled by default. Before executing an OPEN or CLOSE command on a Digital Output, it must be “Armed” first. This is achieved by writing the value 0xFF00 to the appropriate register to “Arm” a particular DO operation. The DO will be “Disarmed” automatically if an “Execute” command is not received within 15 seconds after it has been “Armed”. If an “Execute” command is received without first having received an “Arm” command, the meter ignores the “Execute” command and returns the 0x04 exception code.

Register	Property	Description	Format	Note
9100	WO	Arm DO1 Close	UINT16	Writing “0xFF00” to the register to perform the described action.
9101	WO	Execute DO1 Close	UINT16	
9102	WO	Arm DO1 Open	UINT16	
9103	WO	Execute DO1 Open	UINT16	
9104	WO	Arm DO2 Close	UINT16	
9105	WO	Execute DO2 Close	UINT16	
9106	WO	Arm DO2 Open	UINT16	
9107	WO	Execute DO2 Open	UINT16	

Table 5-51 DO Control

5.15 Clear/Reset Control

Register	Property	Description	Format	Note
9600	WO	Clear Historical Monthly Energy Log ¹	UINT16	Writing “0xFF00” to the register to execute the described action.
9601	WO	Clear All Energy ²		
9602	WO	Clear Present Monthly Energy Log ³		
9603	WO	Clear Peak Demand of This Month ⁴		
9604	WO	Clear All Demand Registers ⁵		
9605	WO	Clear Max./Min. Logs of This Month ⁶		
9606	WO	Clear All Max./Min. Log ⁷		
9607	WO	Clear Device Operating Time		
9608	WO	Clear All Data ⁸		
9609	WO	Clear SOE Log		
9610	WO	Clear DI1 Pulse Counter		

9611	WO	Clear DI2 Pulse Counter		
9612	WO	Clear DI3 Pulse Counter		
9613	WO	Clear DI4 Pulse Counter		
9614~9617	WO	Reserved		
9618	WO	Clear All Pulse Counters		
9619	WO	Clear Data Recorder #1 Log		
9620	WO	Clear Data Recorder #2 Log		
9621	WO	Clear Data Recorder #3 Log		
9622	WO	Clear Data Recorder #4 Log		
9623	WO	Clear Data Recorder #5 Log		
9624	WO	Clear All Data Recorder Log		
9625	WO	Clear Daily Freeze Log		
9626	WO	Clear Monthly Freeze Log		

Table 5-52 Clear Control

Notes:

1. Writing 0xFF00 to the **Clear Historical Monthly Energy Log** register to clear the Monthly Energy Log of the last 1 to 12 months, excluding the Monthly Energy Log for the Present Month.
2. Writing 0xFF00 to the **Clear All Energy** register to clear the 3-Ø Total and Per-Phase energy registers (including TOU Energy).
3. Writing 0xFF00 to the **Clear Present Monthly Energy Log** register to clear the Monthly Energy Log of the Present Month.
4. Writing 0xFF00 to the **Clear Peak Demand Log of This Month** register to clear Peak Demand Log of This Month (Since Last Reset) when the **Self-Read Time** register is set for automatic Self-Read operation. The Peak Demand of Last Month will not be cleared. If the **Self-Read Time** register is set for manual operation with a register value of 0xFFFF, the Peak Demand of This Month (Since Last Reset) will be transferred to the Peak Demand of Last Month (Before Last Reset) and then cleared.
5. Writing 0xFF00 to the **Clear All Demand Registers** register to clear all Demand registers and logs, including Present/Predicted Demand, Peak Demand Log of This Month (Since Last Reset) and Last Month (Before Last Reset).
6. Writing 0xFF00 to the **Clear Max./Min. Log of This Month** register to clear the Max./Min. log of This Month (Since Last Reset) when the **Self-Read Time** register is set for automatic Self-Read operation. The Max./Min. log of Last Month will not be cleared. If the **Self-Read Time** register is set for manual operation with a register value of 0xFFFF, the Max./Min. log of This Month (Since Last Reset) will be transferred to the Max./Min. log of Last Month (Before Last Reset) and then cleared.
7. Writing 0xFF00 to the **Clear All Max./Min. Log** register to clear both the Max./Min Log of This Month (Since Last Reset) and the Max./Min. Log of Last Month (Before Last Reset).
8. Writing 0xFF00 to the **Clear All Data** register to perform the clear operation for all Energy Registers, Monthly Energy Log, Demand Registers, Max. & Min. Logs, SOE Logs, DI Counters, DR Logs, Daily and Monthly Freeze Logs, Setpoint Active Duration and Frequency and Device Operating Time.

5.16 Meter Information

Register	Property	Description	Format	Note	
60200~60219	9800~9819	RO	Meter model ¹	UINT16	See Note 1)
60220	9820	RO	Firmware Version	UINT16	e.g. 10000 shows the version is V1.00.00
60221	9821	RO	Protocol Version	UINT16	e.g. 10 shows the version is V1.0
60222	9822	RO	Firmware Update Date: Year-2000	UINT16	e.g. 140110 means January 10, 2014
60223	9823	RO	Firmware Update Date: Month	UINT16	
60224	9824	RO	Firmware Date: Day	UINT16	
60225	9825	RO	Serial Number	UINT32	e.g. 1901030100 means the 100 th PMC-350-C that was manufactured on January 3 rd , 2019
60227	9827	RO	4M Memory Status	UINT16	0=Normal, 1=Fault
60228	9828	RO	Reserved	UINT16	--
60229	9829	RO	Feature Code	UINT16	See Note 2)

Table 5-53 Meter Information

Notes:

- 1) The Meter Model appears in registers 60200 to 60219 and contains the ASCII encoding of the string “PMC-350-C” as shown in the following table.

Register	Value(Hex)	ASCII
60200	0x0050	P
60201	0x004D	M
60202	0x0043	C

CET Electric Technology

60203	0x002D	-
60204	0x0033	3
60205	0x0035	5
60206	0x0030	0
60207	0x002D	-
60208	0x0043	C
60209-60219	0x0020	Null

Table 5-54 ASCII Encoding of “PMC-350-C”

2) The following table illustrates the details for the Feature Code register.

B8 to B9	B7	B6	B3 to B5 (Communications)	B0 to B2 (Current Input)
0=DO (Mechanical Relay)	0=None	Reserved	0=None	0=SCCT
1=EO (SS Pulse Output)	1=4RTD+1Ir		1~4=Reserved	1=SCCTA
2=None			5=LoRaWAN	

Table 5-55 Feature Code for PMC-350-C

Chapter 6 LoRaWAN Application Protocol

6.1 Introduction

This Chapter provides an explicit description of the LoRaWAN Application Protocol (**Protocol Version 1.0**) for the PMC-350-C to facilitate the data communication with the Application Server.

It allows:

- 1) the PMC-350 to automatically push (Auto-Push) data to the Application Server
- 2) the Application Server to access and configure relevant device settings of the PMC-350

The following table provides a description of the different data formats used for the LoRaWAN Push Protocol. The PMC-350-C uses the Big Endian byte ordering system.

Format	Description
UINT16	Unsigned/Signed 16-bit Integer
UINT32/INT32	Unsigned/Signed 32-bit Integer
Float	IEEE 754 32-bit Single Precision Floating Point Number

For a complete LoRaWAN Protocol Specification, please visit <https://lora-alliance.org/lorawan-for-developers>.

6.2 LoRaWAN Data Packet Definition

The following table illustrates the Auto-Push Packet Definition.

Classification (1 Byte) ¹		Data (X Bytes)
Data Classification (Bits 4-7)	Sub Classification (Bits 0-3)	
1=Energy and Demand	0=None	See Table 6-2
2=Real-time Measurement	1=Basic Measurement	See Table 6-3
	2=Ir and Temperature	See Table 6-4
3=Power Quality	1=Harmonics	See Table 6-5
	2=Basic Power Quality Measurement	See Table 6-6
4=Peak Demand	0=None	See Table 6-7
5=Max./Min. Log of this Month	1=Max. Current/Voltage	See Table 6-8
	2=Min. Current/Voltage	See Table 6-9
	3=Max. Power/Frequency/PF	See Table 6-10
	4=Min. Power/Frequency/PF	See Table 6-11
	5=Max. Ir/Temperature	See Table 6-12
	6=Min. Ir/Temperature	See Table 6-13
6=Max./Min. PQ Log	1=Max. Harmonic	See Table 6-14
	2=Min. Harmonic	See Table 6-15
	3=Max. Current TDD	See Table 6-16
	4=Min. Current TDD	See Table 6-17
	5=Max. K-factor/Crest Factor	See Table 6-18
	6=Min. K-factor/Crest Factor	See Table 6-19
7=Daily Freeze Log	0=None	See Table 6-21
8=Monthly Freeze Log	0=None	See Table 6-22
9=I/O Status	0=None	See Table 6-23

Note:

1. A value of 0xFF is invalid for Classification.

Table 6-1 Data Packet Definition

6.3 LoRaWAN Auto-Push Configuration

Please refer to **Section 5.11.5** for a description of the LoRaWAN Auto-Push Configuration registers.

6.3.1 Packet Structure

6.3.1.1 Energy and Demand

The following table illustrates the packet structure for Energy and Demand data. The Energy registers have a maximum value of 1,000,000,000 and will roll over to zero automatically when it is reached. The actual energy value is 0.01 times of the register value.

Order	Description	Format	Unit
1	Hi: Year (0~99) Lo: Month (1~12)	UINT16	-
	Hi: Day (1~31) Lo: Hour (0~23)	UINT16	
	Hi: Min (0~59) Lo: Reserved	UINT16	
2	kWh Imp	INT32	0.01kxh
3	kWh Exp	INT32	
4	kvarh Imp	INT32	
5	kvarh Exp	INT32	
6	kVAh	INT32	
7	I1 DMD	Float	
8	I2 DMD	Float	
9	I3 DMD	Float	
10	P DMD	Float	W
11	Q DMD	Float	var
12	S DMD	Float	VA

Table 6-2 Energy and Demand Data Structure

6.3.1.2 Real-time Measurement

6.3.1.2.1 Basic Measurement

The following table illustrates the packet structure for Basic Measurement.

Order	Description	Format	Unit
1	Hi: Year (0~99) Lo: Month (1~12)	UINT16	-
	Hi: Day (1~31) Lo: Hour (0~23)	UINT16	
	Hi: Min (0~59) Lo: Reserved	UINT16	
2	I1	Float	A
3	I2	Float	
4	I3	Float	
5	Uab	Float	V
6	Ubc	Float	
7	Uca	Float	
8	P	Float	W
9	Q	Float	var
10	S	Float	VA
11	Frequency	Float	Hz
12	PF	Float	-

Table 6-3 Basic Measurement Structure

6.3.1.2.2 Ir and Temperature

The following table illustrates the packet structure for Ir and Temperature measurement.

Order	Description	Format	Unit
1	Hi: Year (0~99) Lo: Month (1~12)	UINT16	-
	Hi: Day (1~31) Lo: Hour (0~23)	UINT16	
	Hi: Min (0~59) Lo: Reserved	UINT16	
2	IR	Float	mA
3	T1	Float	°C
4	T2	Float	°C
5	T3	Float	°C
6	T4	Float	°C

Table 6-4 Ir and Temperature Measurement Structure

6.3.1.3 Power Quality

6.3.1.3.1 Harmonic

The following table illustrates the packet structure for Harmonic statistics.

Order	Description	Format	Unit
1	Hi: Year (0~99) Lo: Month (1~12)	UINT16	-
	Hi: Day (1~31) Lo: Hour (0~23)	UINT16	
	Hi: Min (0~59) Lo: Reserved	UINT16	
2	I1 THD	Float	100%
3	I2 THD	Float	
4	I3 THD	Float	
5	Uan THD	Float	
6	Ubn THD	Float	
7	Ucn THD	Float	

Table 6-5 Harmonic Measurement Structure

6.3.1.3.2 Basic Power Quality Measurement

The following table illustrates the packet structure for Basic Power Quality measurements.

Order	Description	Format	Unit
1	Hi: Year (0~99) Lo: Month (1~12)	UINT16	-
	Hi: Day (1~31) Lo: Hour (0~23)	UINT16	
	Hi: Min (0~59) Lo: Reserved	UINT16	
2	I1 TDD	Float	100%
3	I2 TDD	Float	
4	I3 TDD	Float	
5	I1 K-Factor	Float	-
6	I2 K-Factor	Float	
7	I3 K-Factor	Float	
8	I1 Crest Factor	Float	
9	I2 Crest Factor	Float	
10	I3 Crest Factor	Float	

Table 6-6 Basic Power Quality Measurement Structure

6.3.1.4 Peak Demand

The following table illustrates the packet structure for Peak Demand measurements.

Order	Description	Format	Unit
1	I1 DMD_MAX	LOG	A
2	I2 DMD_MAX	LOG	
3	I3 DMD_MAX	LOG	
4	P DMD_MAX	LOG	W
5	Q DMD_MAX	LOG	var
6	S DMD_MAX	LOG	VA

Table 6-7 Peak Demand Measurement Structure

6.3.1.5 Max./Min.

6.3.1.5.1 Max. Current and Voltage

The following table illustrates the packet structure for Max. Current and Voltage measurements.

Order	Description	Format	Unit
1	I1_MAX	LOG	A
2	I2_MAX	LOG	
3	I3_MAX	LOG	
4	U1_MAX	LOG	V
5	U2_MAX	LOG	
6	U3_MAX	LOG	

Table 6-8 Max. Current and Voltage Measurement Structure

6.3.1.5.2 Min. Current and Voltage

The following table illustrates the packet structure for Min. Current and Voltage measurements.

Order	Description	Format	Unit
1	I1_MIN	LOG	A
2	I2_MIN	LOG	
3	I3_MIN	LOG	
4	U12_MIN	LOG	V
5	U23_MIN	LOG	
6	U31_MIN	LOG	

Table 6-9 Min. Current and Voltage Measurement Structure

6.3.1.5.3 Max. Power/Frequency/Power Factor

The following table illustrates the packet structure for Max. Power/Frequency/PF measurements.

Order	Description	Format	Unit
1	P_MAX	LOG	W
2	Q_MAX	LOG	var
3	S_MAX	LOG	VA
4	Freq_MAX	LOG	Hz
5	PF_MAX	LOG	

Table 6-10 Max. Power/Frequency/Power Factor Measurement Structure

6.3.1.5.4 Min. Power/Frequency/Power Factor

The following table illustrates the packet structure for Min. Power/Frequency/PF measurements.

Order	Description	Format	Unit
1	P_MIN	LOG	W
2	Q_MIN	LOG	var
3	S_MIN	LOG	VA
4	Freq_MIN	LOG	Hz
5	PF total_MIN	LOG	

Table 6-11 Min. Power/Frequency/Power Factor Measurement Structure

6.3.1.5.5 Max. Ir and Temperature

The following table illustrates the packet structure for Max. Ir and Temperature measurements.

Order	Description	Format	Unit
1	IR_MAX	LOG	mA
2	T1_MAX	LOG	°C
3	T2_MAX	LOG	°C
4	T3_MAX	LOG	°C
5	T4_MAX	LOG	°C

Table 6-12 Max. Ir and Temperature Measurement Structure Min. Ir and Temperature

6.3.1.5.6 Min. Ir and Temperature

The following table illustrates the packet structure for Min. Ir and Temperature measurements.

Order	Description	Format	Unit
1	IR_MIN	LOG	mA
2	T1_MIN	LOG	°C
3	T2_MIN	LOG	°C
4	T3_MIN	LOG	°C
5	T4_MIN	LOG	°C

Table 6-13 Min. Ir and Temperature Measurement Measurement Structure

6.3.1.5.7 Max. Harmonic

The following table illustrates the packet structure for Max. Harmonic measurements.

Order	Description	Format
1	I1 THD_MAX	LOG
2	I2 THD_MAX	LOG
3	I3 THD_MAX	LOG
4	U1 THD_MAX	LOG
5	U2 THD_MAX	LOG
6	U3 THD_MAX	LOG

Table 6-14 Max. Harmonic Measurement Structure

6.3.1.5.8 Min. Harmonic

The following table illustrates the packet structure for Min. Harmonic measurements.

Order	Description	Format
1	I1 THD_MIN	LOG
2	I2 THD_MIN	LOG
3	I3 THD_MIN	LOG
4	U1 THD_MIN	LOG
5	U2 THD_MIN	LOG
6	U3 THD_MIN	LOG

Table 6-15 Min. Harmonic Measurement Structure

6.3.1.5.9 Max. Current TDD

The following table illustrates the packet structure for Max. Current TDD measurements.

Order	Description	Format
1	I1 TDD_MAX	LOG
2	I2 TDD_MAX	LOG
3	I3 TDD_MAX	LOG

Table 6-16 Max. Current TDD Measurement Structure

6.3.1.5.10 Min. Current TDD

The following table illustrates the packet structure for Min. Current TDD measurements.

Order	Description	Format
1	I1 TDD_MIN	LOG
2	I2 TDD_MIN	LOG
3	I3 TDD_MIN	LOG

Table 6-17 Min. Current TDD Measurement Structure

6.3.1.5.11 Max. Current K-Factor and Crest Factor

The following table illustrates the packet structure for Max. Current K-Factor and Crest Factor measurements.

Order	Description	Format
1	I1 K-Factor_MAX	LOG
2	I2 K-Factor_MAX	LOG
3	I3 K-Factor_MAX	LOG
4	I1 Crest Factor_MAX	LOG
5	I2 Crest Factor_MAX	LOG
6	I3 Crest Factor_MAX	LOG

Table 6-18 Max. Current K-Factor and Crest Factor Measurement Structure

6.3.1.5.12 Min. Current K-Factor and Crest Factor

The following table illustrates the packet structure for Min. Current K-Factor and Crest Factor measurements.

Order	Description	Format
1	I1 K-Factor_MIN	LOG
2	I2 K-Factor_MIN	LOG
3	I3 K-Factor_MIN	LOG
4	I1 Crest Factor_MIN	LOG
5	I2 Crest Factor_MIN	LOG
6	I3 Crest Factor_MIN	LOG

Table 6-19 Min. Current K-Factor and Crest Factor Measurement Structure

6.3.1.6 Log Data Structure

The following table illustrates the **Peak Demand Log** and **Max./Min. Log** Data Structure.

Offset	Format	Description
+0~3	UINT32	UNIX Timestamp
+4~7	Float	Value

Table 6-20 Log Data Structure

6.3.1.7 Daily Freeze Log

The following table illustrates the packet structure for Daily Freeze Log.

Order	Description	Format	Unit
1	Hi: Year (0~99) Lo: Month (1~12)	UINT16	-
	Hi: Day (1~31) Lo: Hour (0~23)	UINT16	
	Hi: Min (0~59) Lo: Reserved	UINT16	
2	kWh Import	INT32	0.01kxh
3	kvarh Import	INT32	
4	kVAh	INT32	

Table 6-21 Daily Freeze Log Structure

6.3.1.8 Monthly Freeze Log

The following table illustrates the packet structure for Monthly Freeze Log.

Order	Description	Format	Unit
1	Hi: Year (0~99) Lo: Month (1~12)	UINT16	
	Hi: Day (1~31) Lo: Hour (0~23)	UINT16	
	Hi: Min (0~59) Lo: Reserved	UINT16	
2	kWh Import	INT32	0.01kxh
3	kvarh Import	INT32	
4	kVAh	INT32	

Table 6-22 Monthly Freeze Structure

6.3.1.9 I/O Status

The following table illustrates the packet structure for I/O Status.

Order	Description	Format
1	Hi: Year (0~99) Lo: Month (1~12)	UINT16
	Hi: Day (1~31) Lo: Hour (0~23)	UINT16
	Hi: Min (0~59) Lo: Reserved	UINT16
2	msec	UINT16
2	DI Status ¹	UINT16
3	DO Status ²	UINT16

4	Ir Self-diagnostic Status ³	UINT16
5	Temp. Self-diagnostic Status ⁴	UINT16
6~10	Reserved	UINT16
11	Setpoint Active Status ⁵	UINT16

Table 6-23 I/O Status Structure

Notes:

1. For the **DI Status** register, the bit values of B0 to B3 represent the states of DI1 to DI4, respectively, with “1” meaning Active (Closed) and “0” meaning Inactive (Open).
2. For the **DO Status** register, the bit values of B0 to B1 represent the states of DO1 and DO2, respectively, with “1” meaning DO Operated and “0” meaning DO Returned.
3. For the **Ir Self-diagnostic Status** register, the bit values of B0 represents the states of external CT for Ir with “1” meaning faulty and “0” meaning normal.
4. For the **Temp. Self-diagnostic Status** register, the bit values of B0 to B3 represents the states of external Temperature Probe for TC1 to TC4, respectively, with “1” meaning faulty and “0” meaning normal.
5. For the **Setpoint Status** register, the bit values indicate the various Setpoint states with “1” meaning Active and “0” meaning Inactive. The following table illustrates the details of the **Alarm Status** register.

Bit15	Bit14	Bit13	Bit12	Bit11	Bit10	Bit9	Bit8
Reserved	Reserved	Reserved	Reserved	Reserved	Reserved	Setpoint10	Setpoint9
Bit7	Bit6	Bit5	Bit4	Bit3	Bit2	Bit1	Bit0
Setpoint8	Setpoint7	Setpoint6	Setpoint5	Setpoint4	Setpoint3	Setpoint2	Setpoint1

Table 6-24 Alarm Status register

6.4 Application Server

The application server can also initiate data read and write requests to the LoRaWAN meter using the Modbus protocol as the “Payload”. In this case the Modbus Unit ID is fixed at 248, and the maximum Modbus RTU packet size must be less than 50 bytes. It should be noted that this mechanism is supported mainly to allow the Application Server to make minor configuration changes to the LoRaWAN configuration of the node on an exception basis. This mechanism is not intended to be used for the polling of real-time data from the node on a regular basis.

6.4.1 Application Server Request Format

The application server request frame format is described as follows:

Field	Length	Description
Application Server Request Frame Number	1 byte	For each frame request message sent by the application server, the count is incremented by 1. Every cycle is incremented by 1 from 0 to 255
PayLoad Section	X bytes	Modbus RTU request message

Table 6-25 Application Server Request Format

6.4.2 Node Response Format

The PayLoad section of the node response frame is described as follows:

Field	Length	Description
Send Frame Type	1 byte	Fixed to the value of 0xFF; indicates that the node replies to the application server request frame (different from active delivery frame)
Node Response Frame Number	1 byte	Equals to Application Server Request Frame Number
PayLoad Section	Y bytes	Modbus RTU response message not exceeding 50 bytes

Table 6-26 Node Response Format

Appendix A Data Recorder Parameter List

ID	Description	ID	Description	ID	Description
Real-time Measurements (Format: Float)					
0	None	14	kWb	28	PF Total
1	Uan	15	kWc	29	Frequency
2	Ubn	16	kW Total	30	Uan/Uab Angle
3	Ucn	17	kvara	31	Ubn/Ubc Angle
4	Uln Average	18	kvarb	32	Ucn/Uca Angle
5	Uab	19	kvarc	33	Ia Angle
6	Ubc	20	kvar Total	34	Ib Angle
7	Uca	21	kVAa	35	Ic Angle
8	Ull Average	22	kVAb	36	In (Calculated)
9	Ia	23	kVAc	37	Ir
10	Ib	24	kVA Total	38	TC1
11	Ic	25	PFa	39	TC2
12	I Average	26	PFb	40	TC3
13	kWa	27	PFc	41	TC4
Power Quality (Format: Float)					
60	Phase A Fundamental kW	78	Ib Crest -Factor	179	Ubn/Ubc HD31
61	Phase B Fundamental kW	79	Ic Crest -Factor	180	Ucn/Uca HD31
62	Phase C Fundamental kW	80	Voltage Unbalance	181	Ia THD
63	Fundamental kW Total	81	Current Unbalance	182	Ib THD
64	Total Harmonic kW	82	Uan/Uab THD	183	Ic THD
65	Ia TDD	83	Ubn/Ubc THD	184	Ia TOHD
66	Ib TDD	84	Ucn/Uca THD	185	Ib TOHD
67	Ic TDD	85	Uan/Uab TOHD	186	Ic TOHD
68	Ia TOHD	86	Ubn/Ubc TOHD	187	Ia TEHD
69	Ib TOHD	87	Ucn/Uca TOHD	188	Ib TEHD
70	Ic TOHD	88	Uan/Uab TEHD	189	Ic TEHD
71	Ia TEHD	89	Ubn/Ubc TEHD	190	Ia HD02
72	Ib TEHD	90	Ucn/Uca TEHD	191	Ib HD02
73	Ic TEHD	91	Uan/Uab HD02	192	Ic HD02
74	Ia K-Factor	92	Ubn/Ubc HD02
75	Ib K-Factor	93	Ucn/Uca HD02	277	Ia HD31
76	Ic K-Factor	278	Ib HD31
77	Ia Crest Factor	178	Uan/Uab HD31	279	Ic HD31
Energy Measurements (Format: INT32)					
300	DI1 Pulse Counter	314	kVAh	328	kVAh of T2
301	DI2 Pulse Counter	315	kvarh Q1
302	DI3 Pulse Counter	316	kvarh Q2	354	kWh Import of T8
303	DI4 Pulse Counter	317	kvarh Q3	355	kWh Export of T8
304	Reserved	318	kvarh Q4	356	kvarh Import of T8
305		319	kWh Import of T1	357	kvarh Export of T8
306	kWh Import	320	kWh Export of T1	358	kVAh of T8
307	kWh Export	321	kvarh Import of T1	359	kWh _a Import
308	kWh Net	322	kvarh Export of T1	360	kWh _b Import
309	kWh Total	323	kVAh of T1	361	kWh _c Import
310	kvarh Import	324	kWh Import of T2	362	kvarh _a Import
311	kvarh Export	325	kWh Export of T2	363	kvarh _b Import
312	kvarh Net	326	kvarh Import of T2	364	kvarh _c Import
313	kvarh Total	327	kvarh Export of T2		
Demand Measurements (Format: Float)					
320	Ia Present Demand	326	Ia Peak Demand Log of This Month (Since Last Reset)		
321	Ib Present Demand	327	Ib Peak Demand Log of This Month (Since Last Reset)		
322	Ic Present Demand	328	Ic Peak Demand Log of This Month (Since Last Reset)		
323	kW Total Present Demand	329	kW Peak Demand Log of This Month (Since Last Reset)		
324	kvar Total Present Demand	330	kvar Peak Demand Log of This Month (Since Last Reset)		
325	kVA Total Present Demand	331	kVA Peak Demand Log of This Month (Since Last Reset)		

Appendix B Data Recorder Default Settings

Parameter	DR 1	DR 2	DR 3	DR 4	DR 5
Trigger Mode	Triggered by Timer	Triggered by Timer	Triggered by Timer	Triggered by Timer	Triggered by Timer
Recording Mode	FIFO	FIFO	FIFO	FIFO	FIFO
Recording Depth	5760	5760	5760	5760	5760
Recording Interval	900s	900s	900s	900s	900s
Recording Offset	0	0	0	0	0
Number of Parameters	15	16	16	15	16
Parameter 1	kWh Import	Uab	Uan	Uan/Uab THD	T1 kWh Imp.
Parameter 2	kWh Export	Ubc	Ubn	Ubn/Ubc THD	T1 kWh Exp.
Parameter 3	kWh Total	Uca	Ucn	Ucn/Uca THD	T1 kvarh Imp.
Parameter 4	kWh Net	Ull avg	Uln avg	Ia THD	T1 kvarh Exp.
Parameter 5	kvarh Import	Ia	kWa	Ib THD	T2 kWh Imp.
Parameter 6	kvarh Export	Ib	kWb	Ic THD	T2 kWh Exp.
Parameter 7	kvarh Total	Ic	kWc	Ia TDD	T2 kvarh Imp.
Parameter 8	kvarh Net	I avg	kvara	Ib TDD	T2 kvarh Exp.
Parameter 9	kVAh Total	Inc	kvarb	Ic TDD	T3 kWh Imp.
Parameter 10	kW Total Demand	kW Total	kvarc	Ia K-Factor	T3 kWh Exp.
Parameter 11	kvar Total Demand	kvar Total	kVAa	Ib K-Factor	T3 kvarh Imp.
Parameter 12	kVA Total Demand	kVA Total	kVAb	Ic K-Factor	T3 kvarh Exp.
Parameter 13	Ia Demand	PF Total	kVAc	Ia Crest Factor	T4 kWh Imp.
Parameter 14	Ib Demand	Freq.	PFa	Ib Crest Factor	T4 kWh Exp.
Parameter 15	Ic Demand	U Unbalance	PFb	Ic Crest Factor	T4 kvarh Imp.
Parameter 16	None	I Unbalance	PFc	None	T4 kvarh Exp.

Appendix C Technical Specifications

Voltage Inputs (V1, V2, V3, VN)		
Voltage (Un)	277VLN/480VLL	
Range	90V to 1.2 Un	
Burden	<2W/phase	
Frequency	45-65Hz	
Current Inputs (I11, I12, I21, I22, I31, I32)		
Current (In)	SCCT Option 40mA	SCCTA Option 2mA
Range	0.15%-100% In	0.1%-120% In
Starting Current	0.15% In	0.1% In
Burden	<0.25VA per phase	<0.25VA per phase
External SCCTs	100A/40mA 200A/40mA 400A/40mA 800A/40mA 1600A/40mA	5A/2mA
Power Supply (L/+, N/-)		
Standard	95-250VAC/DC, ±10%, 47-440Hz	
Burden	<2W	
Overvoltage Category	CAT III up to 300VLN	
Optional Digital Inputs (DI1, DI2, DI3, DI4, DIC)		
Type	Dry contact, 24VDC internally wetted	
Sampling	1000Hz	
Hysteresis	1ms minimum	
Optional Digital Outputs (DO11, DO12, DO21, DO22)		
Type	Form A Mechanical Relay	
Loading	5A @ 250VAC or 30VDC	
Optional RTD Temperature Inputs (TC1, TC2, TC3, TC4)		
RTD Type	2-Wire PT100 (sensor not included)	
PT100	-40-200°C	
Alarm Range	45-140°C	
Optional Residual Current Inputs (·IR, IR)		
Range	20mA-2000mA	
Optional Energy Pulse Output (E1+, E1-, E2+, E2-) Selectable kWh/kvarh		
Pulse Constant	10/100/1000/3200 imp/kxh	
Isolation	Optical	
Max. Load Voltage	80V	
Max. Forward Current	50mA	
Pulse Width	80±20ms	
Communications		
RS-485 (Standard) Protocol	Modbus RTU	
Baudrate	1200/2400/4800/9600/19200/38400 bps	
LoRaWAN (Optional)	LoRaWAN™ Specification 1.0.2 Class A/C Compliance	
ISM Bands AS923/KR920/EU868	Asia Pacific: Australia, Brunei, Cambodia, Hong Kong, Indonesia, Japan, Laos, Malaysia, New Zealand, Singapore, Taiwan, Thailand and South Korea (KR920) South America: Bolivia, Chile, Costa Rica, Ecuador, Guatemala, Panama, Paraguay, Peru, Salvador, Uruguay and Venezuela Others: Europe, Pakistan and Uganda	
Environmental Conditions		
Operating temp.	-25°C to +70°C	
Storage temp.	-40°C to +85°C	
Humidity	5% to 95% non-condensing	
Atmospheric pressure	70 kPa to 106 kPa	
Pollution Degree	2	
Mechanical Characteristics		
Mounting	DIN Rail or optional Panel Mount	
Unit Dimensions (W×H×D)	72x95x70mm	
Pannel Cutout	78x67mm	
IP Rating	IP30	

Accuracy

Parameters	Accuracy	Resolution
Voltage	±0.5%	0.01V
Current	±0.5%	0.001A
kW, kvar, kVA	±1.0%	0.001kW/kvar/kVA
kWh	IEC 62053-21:2003 Class 1	0.01kWh
kvarh	IEC 62053-23:2003 Class 2	0.01kvarh
P.F.	±1.0%	0.001
Frequency	±0.02Hz	0.01Hz
In (Calculated)	±1.0%	0.001A
THD	IEC 61000-4-7 Class B	0.001%
Iresidual	±1.0%	0.1mA
Temperature	±1°C	0.1°C

Appendix D Standards of Compliance

Safety Requirements	
CE LVD 2014 / 35 / EU	EN 61010-1: 2010 EN 61010-2-030: 2010
Electrical safety in low voltage distribution systems up to 1000Vac and 1500 Vdc	IEC 61557-12: 2018 (PMD)
Insulation AC Voltage: 2kV @ 1 minute Insulation resistance: >100MΩ Impulse Voltage: 6kV, 1.2/50μs	IEC 62052-11: 2003 IEC 62053-22: 2003
Electromagnetic Compatibility CE EMC Directive 2014 / 30 / EU (EN 61326: 2013)	
Immunity Tests	
Electrostatic Discharge	EN 61000-4-2: 2009
Radiated Fields	EN 61000-4-3: 2006+A1: 2008+A2: 2010
Fast Transients	EN 61000-4-4: 2012
Surges	EN 61000-4-5: 2014+A1:2017
Conducted Disturbances	EN 61000-4-6: 2014
Magnetic Fields	EN 61000-4-8: 2010
Voltage Dips and Interruptions	EN 61000-4-11:2004+A1:2017
Emission Tests	
Limits and methods of measurement of electromagnetic disturbance characteristics of industrial, scientific and medical (ISM) radio-frequency equipment	EN 55011: 2016
Limits and methods of measurement of radio disturbance characteristics of information technology equipment	EN 55032:2015
Limits for harmonic current emissions for equipment with rated current ≤16 A	EN 61000-3-2: 2014
Limitation of voltage fluctuations and flicker in low-voltage supply systems for equipment with rated current ≤16 A	EN 61000-3-3: 2013
Emission standard for residential, commercial and light-industrial environments	EN 61000-6-4: 2007+A1: 2011
Mechanical Tests	
Spring Hammer Test	IEC 62052-11: 2003
Vibration Test	IEC 62052-11: 2003
Shock Test	IEC 62052-11: 2003

Appendix E Ordering Guide

 CET Electric Technology		<i>Version 20211215</i>									
Product Code		Description									
PMC-350		3-Phase LoRaWAN DIN Energy Meter									
Basic Function											
C		Multifunction Measurements, LCD Display, 1xRS-485									
Input Current											
SCCT		40mA Input for use with 100A/40mA, 200A/40mA, 400A/40mA, 800A/40mA or 1600A/40mA SCCTs (SCCTs not included)									
SCCTA		2mA Input for use with 5A/2mA SCCT (SCCTs not included)									
Input Voltage											
5		277VLN/480VLL + 20% (1P2W UIn, 1P2W UII, 1P3W, 3P3W, 3P4W, Demo)									
Power Supply											
2		95-250 VAC/VDC, 47-440Hz									
Frequency											
5		45-65Hz									
Expansion 1*											
N		None									
A		4xDI + 2xDO (Mechanical Relay)									
B		4xDI + 2xSS Pulse Output									
Expansion 2*											
N		None									
T		4xRTD + 1xResidual Inputs									
Expansion Communication*											
N		None									
1		LoRaWAN @ EU868 with External Antenna									
6		LoRaWAN @ AS923 with Internal Antenna									
7		LoRaWAN @ AS923 with External Antenna									
Language											
E		English									
PMC-350	-	C	SCCT	5	2	5	N	N	7	E	PMC-350-CSCCT525NN7E (Standard Model)

* Additional charges apply

		CET Electric Technology			Version 20211220
PMC-350-C Accessories					
External Split-Core CT					
Model #	Specification	Accuracy	Dimension (mm)	Cable Length	
PMC-SCCT-100A-40mA-16-A	100A, 1-Phase Split-Core CT with 2m Cable & Pluggable Connector	0.5	Round hole, ϕ 16	2m	
PMC-SCCT-200A-40mA-24-A	200A, 1-Phase Split-Core CT with 2m Cable & Pluggable Connector	0.5	Round hole, ϕ 24	2m	
PMC-SCCT-400A-40mA-35-A	400A, 1-Phase Split-Core CT with 2m Cable & Pluggable Connector	0.5	Round hole, ϕ 35	2m	
PMC-SCCT-800A-40mA-A	800A, 1-Phase Split-Core CT with PMC-BCC-350-2	0.5	Square hole 80x50mm	2m	
PMC-SCCT-1600A-40mA-A	1600A, 1-Phase Split-Core CT with PMC-BCC-350-2	0.5	Square hole 130x55mm	2m	
PMC-SCCT-5A-2mA-16-A	5A/2mA, 1-Phase Split-Core CT with 2m Cable & Pluggable Connector	2	Round hole, ϕ 16	2m	
Cable for 800A/1600A Split-Core CT					
Model #	Specification				
PMC-BCC-350-2	2m with 2-Pin Black Pluggable Connector for 800A and 1600A SCCTs				
DIN Panel Mounting Adapter					
Model #	Specification				
PMC-PMA-4	Panel Mounting Adapter for 4P DIN-Rail Mounting devices				

- 1) Please refer to Cable Length for details and contact the factory in advance for special requirements.
- 2) One PMC-350-C can be equipped with 3 pcs of SCCT.
- 3) "PMC-PMA-4" is only applicable for the PMC-350-C with Internal Antenna.

Contact us

CET Electric Technology Inc.

Email: support@cet-global.com

Web: www.cet-global.com